



# Product Brochure

[REIDLIFTING.COM](http://REIDLIFTING.COM)





## > Contents

### 04 About REID

06 Around the world

06 Who we work with

08 Dedicated training

09 Quality & safety

### 10 Gantry systems

12 PORTAGANTRY

20 PORTAGANTRY Load Baring Pneumatic Castor Model

24 PORTAGANTRY **RAPIDE**

30 Accessories

### 32 Davit Systems

34 TDAVIT

40 TDAVIT TDT

44 TDAVIT TDVW

48 PORTADAVIT

52 PORTADAVIT **QUANTUM**

56 Accessories

### 58 Bases & Sockets

60 PORTABASE

74 Sockets & Extensions

78 Custom solutions

# Making light work of **lifting** and **lowering**.

Since 1996, REID Lifting have been combining innovative design with expert engineering to create lightweight, portable, aluminium lifting systems that help our customers to achieve their operational and safety objectives efficiently and effectively.

From our headquarters in Monmouthshire, in the United Kingdom, we expertly engineer our systems through the use of lightweight aluminium as an alternative to steel, setting a precedent for innovation and successful experimentation, leading us to become one of the global pioneers in lifting technology today.

Many of our products are patented and have become the industry-standard for lifting solutions, trusted by many leading companies in more than 50 countries around the world.

We have been duly recognised for our innovative contributions to the lifting industry, winning four prestigious Queens Awards for Innovation and International Trade,

as well as being recognised as one of the UK's leading exporters.

Here at REID Lifting, we welcome the opportunity to work with clients to successfully meet your lifting needs from our core range of products. Should you require a special solution for a unique circumstance, we can also develop custom solutions to help meet your needs.



## ► Our icons explained

On each product page, these icons will help you understand more about the system, its capabilities, and limitations.



### Capacity

Each system will have a capacity rating clearly stated along with its serial number for traceability. The WLL rating should NOT be exceeded under any circumstances.



### People required for assembly / operation

An indicator of the people typically required to safely assemble and operate the system in normal situations within manual handling guidelines. Every lift should be supported by the relevant risk assessment and method statement prior to the activity.



### Transportation weight / method

The typical total weight of each system for transportation. Weights may vary marginally. The format explains whether the system is 'bagged' or 'flat packed' for easy and safe storage, handling and transportation.



### EN795 certified for personnel lifting

Fully certified temporary anchor point meeting strict requirements of EN795:2012 for protection against falls from a height and personnel lifting [as part of an EN363 compliant system].



### ATEX certified

The capability of equipment to work within an explosive atmosphere. Please contact REID for further details.





## ➤ Around the world

We have a carefully selected network of professional and highly experienced distributors and re-sellers across the globe. We have key distributors in the following countries:

- USA
- Canada
- France
- Germany
- Switzerland
- Italy
- Sweden
- Australia

For more information about our partners and how we can to connect you for local service please email [enquiries@reidlifting.com](mailto:enquiries@reidlifting.com)

## > Who we work with

We have built an exceptional reputation for designing high-quality and resilient products for use across a diverse range of industries including;

- > Water and Wastewater
- > Oil and Gas
- > Height Safety
- > Petrochemical
- > Renewable Energy
- > Aviation
- > Automotive
- > Construction
- > Food Processing
- > And even Museums, where our products are trusted for lifting priceless pieces of art.

Our expertise knows no bounds and, as a result, our products are used far and wide in industries throughout 50 countries around the world. There are no limits to the industries we serve.



## > Dedicated training

We're not just product providers. It's important to us that our products are used as effectively and safely as possible, which is why we offer training for our full range of systems.

Our training is tailored to your needs and designed to make sure everybody knows how to safely assemble and use our systems. If you would like to find more about our training sessions, contact us on [training@reidlifting.com](mailto:training@reidlifting.com)

Head to our website where you can find a range of informative resources from product assembly videos to Assembly & Operation Guides all of which are designed to support our customers in safely and effectively operating and assembling our products.

[REIDLIFTING.COM](http://REIDLIFTING.COM)







## ➤ Quality & Safety, Guaranteed

All of our products are rigorously tested for our customers benefit before they leave our factory in order to guarantee superior performance. REID products are built to last.

We operate an Integrated Management System certified by a UKAS accredited third party certification body to:

- ISO 9001:2015 – Quality Management System
- ISO 14001:2015 – Environmental Management System
- ISO 45001 – Health & Safety Management System

All REID products are designed by engineers with many years' experience in the lifting industry which underpins the Integrated Management System.

All products undergo thorough testing to prove functional and safety compliance. This includes working with Notified Bodies to prove compliance with National and International Standards such as EN795:2012.

REID are also proud to be a member of the Lifting Equipment Engineers Association.

### Product Warranty

REID products are guaranteed for 10 years (see terms and conditions for further details)





# Gantry Systems

Innovative, convenient and easy to assemble, our two Gantry systems – the **PORTAGANTRY** and **PORTAGANTRY<sup>RAPIDE</sup>** – effortlessly enable safe lifting to take place in a wide range of working environments.

**12**    **PORTAGANTRY**

**20**    **PORTAGANTRY** Load Baring Pneumatic Castor Model

**24**    **PORTAGANTRY<sup>RAPIDE</sup>**



# PORTAGANTRY®



Engineered designs and bespoke sections reduce weight, providing lightweight portability

Carrying WLL of up to 5000kg for goods lifting

Ease of height adjustment with integrated ratchet

Approved for up to 5 persons for fall protection applications

Ease of assembly including height and span adjustment

Stabiliser legs for ease of transportation and stowage of the A-frame

Ergonomic 360° swivel-locking castors, as standard

This product is patented

\* Visit our website for our product assembly videos to find out how easy our **PORTAGANTRY** range can be assembled in the field.

Our top quality and highly durable **PORTAGANTRY** is lightweight and extremely strong. This portable system can be manually assembled, using just four bolts and can safely lift up to 5000kg, making it the ideal system for multiple applications.

## Key features

- › EN795:2012 Certified
- › ATEX Certified
- › Can support goods and personnel lifting;
  - › Goods WLL of up to 5000kg
  - › Personnel WLL of up to 2500kg
- › Suitable for up to 5 persons for fall protection applications
- › Beams and A-Frames can be interchanged
- › Ergonomic 360° swivel-locking castors, as standard
- › Ease of assembly including height and span adjustment
- › Anodised for increased corrosion resistance
- › Engineered designs and bespoke sections reduce weight, providing lightweight portability

## Configurations

The **PORTAGANTRY** is available in a range of configurations and can be customised in line with specific requirements (subject to WLL rating).

The **PORTAGANTRY** has the ability to be moved under load. (Subject to detailed instruction and supervision by a competent person).



**500-5000KG  
WLL**



**1-4 PERSON  
ASSEMBLY**



**92-294KG  
FLAT PACK**



**EN795  
CERTIFIED**



**ATEX  
CERTIFIED**

## Features & Performance

	500	1000	2000	3000	5000
<b>Accreditations, Certifications &amp; Standards</b>					
EN795:2012	✓	✓	✓	✓	✓
PD CEN / TS16415:2013	✓	✓	✓	✓	✓
ANSI Z359.18-17	✓	✓	✓	✓	✓
AS/NZS 5532:2013	✓	✓	✓	✓	✓
ATEX Certified [Zone 2]	✓	✓	✓	✓	✓
ATEX Certified [Zone 1]	Optional	Optional	Optional	Optional	×
IRATA	✓	✓	✓	✓	✓
<b>Capacity</b>					
Maximum Goods Lifting [kg]	500	1000	2000	3000	5000
Maximum Personnel Lifting [kg]	250	500	1000	1500	2500
Fall Arrest [Persons]	3	3	5	5	5
<b>Dimensions</b>					
Minimum Height of Lift [mm]	1605	1605	1605	1660	2181
Maximum Height of Lift [mm]	5829	5829	5829	5527	5000
Minimum Available Span [mm]	2500	2500	2500	2500	2500
Maximum Available Span [mm]	9000	9000	8400	8400	5500
<b>Trolley Options</b>					
Standard	✓	✓	✓	✓	✓
Gated	✓	✓	✓	✓	✓
Close Coupled	✓	✓	✓	✓	×
Gear Driven	✓	✓	✓	×	×
Integrated Hoist	✓	✓	✓	×	×
<b>Standard Features</b>					
Ratchet Height Adjustment	✓	✓	✓	✓	✓
Mechanical aid Assembly	×	×	×	×	✓
<b>Optional Extras</b>					
Lobed Cheek Plates	✓	✓	✓	✓	✓
Winch Upgrade	✓	✓	✓	✓	✓
Wind Up Jack legs	✓	✓	✓	✓	✓
Trolley Rope Control System	✓	✓	✓	✓	✓
Festoon System	✓	✓	✓	✓	✓
Jointed Beam	✓	✓	×	×	×
Directional Lock Castors	✓	✓	✓	✓	✓
Shackled Cheek Plates	✓	✓	✓	✓	✓
<b>Finishes</b>					
Anodised	✓	✓	✓	✓	✓
316SS Fixings	Optional	Optional	Optional	Optional	Optional
Marine Spec	Optional	Optional	Optional	Optional	×

Dimensions in the table are approximate values. For more accurate details please refer to the Dimension Table.

All line items marked with a '✓' come as standard. All line items marked with a 'X' are not available.

All line items marked with 'optional' are available as an option and may incur additional costs.

## PORTAGANTRY® 500-5000

- A** Beam length
- B** Beam adjustment
- C** Clear operating span
- D** Height to lifting eye
- E** Height increment
- F** Height to top of beam
- G** Width
- H** Height to top of roller

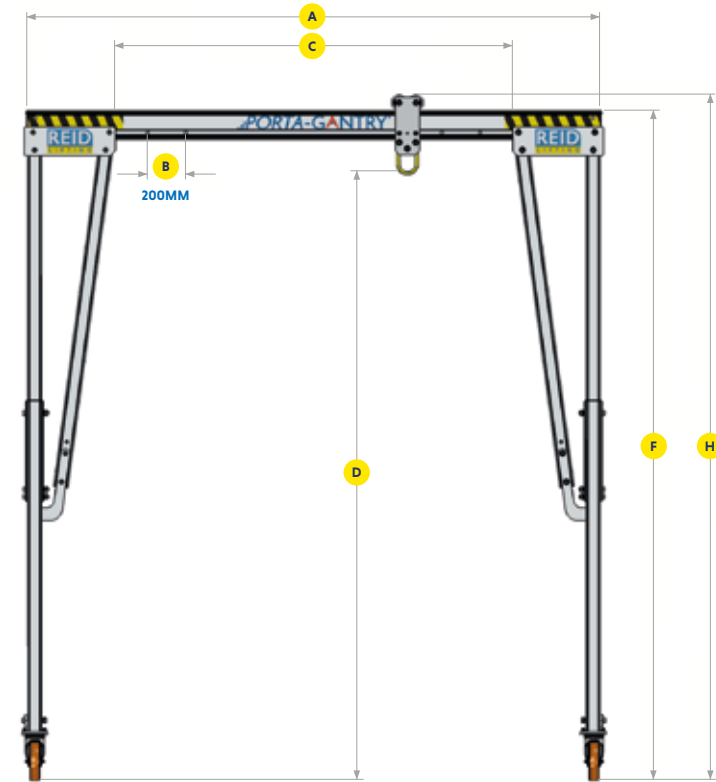
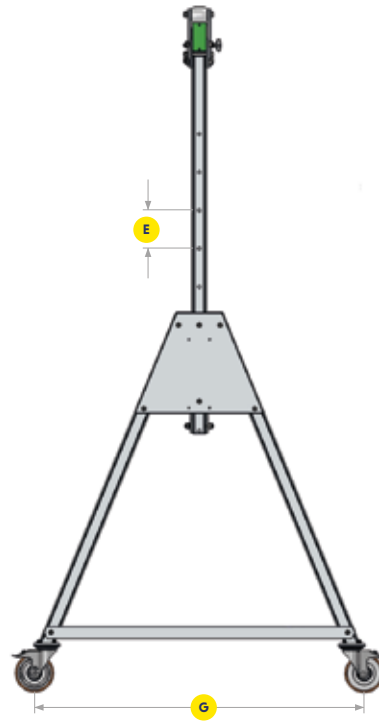

Standard Beam Length A[mm] (Clear Operating Span C = A - 920 mm)

A [mm]	2500	3000	3920	4570	5500	6000	8400	9000
C [Min] [mm]	1180	1680	2200	2050	2980	3480	5880	6480
C [Max] [mm]	1580	2080	3000	3650	4580	5080	7480	8080
WLL Rating [kg]								
500	19	22	29	34	41	44	62	66
1000	19	22	29	34	41	44	79	84
2000	19	22	29	34	52	93*	130*	x
3000	19	22	37	43	85*	93*	130*	x
5000	39*	47*	61*	71*	85*	x	x	x



To ensure stability of the structure, the operating span of the beam must be equal to or greater than the distance between the castors on the A-frame

Weight of Beams [kg]

\*Clear operating span for D section beams is C = A - 910mm.

Dimensions [mm]

WLL [kg]	Frame size [Product Code]	DMax Height to lifting eye	E Height increment		DMin Height to lifting eye	FMax Height to top of beam	HMax Height to top of roller	HMin Height to top of roller	G Width	A-Frame weight (kg) (approx)	Trolley roller size	Castor Diam
500	PGAS00500S	2345	5 x 150	M	1595	2675	2757	2007	1212	32	82	150
	PGAS00500M	2841	5 x 150	M	2091	3171	3253	2503	1429	42	82	150
	PGAS00500I	3178	5 x 200	M	2178	3499	3581	2581	1726	50	82	200
	PGAS00500T	4069	6 x 200	R	2869	4399	4481	3281	2011	56	82	200
	PGAS00500TC4	4517	6 x 200	R	3317	4847	4930	3730	2234	86	82	200
	PGAS00500TC3	5017	6 x 200	R	3817	5347	5430	4230	2557	91	82	200
	PGAS00500TC2	5517	8 x 200	R	3917	5848	5930	4330	2733	97	82	200
PGAS00500TC1	5819	9 x 200	R	4019	6149	6231	4431	2733	102	82	200	
1000	PGAS01000S	2345	5 x 150	M	1595	2675	2757	2007	1212	32	82	150
	PGAS01000M	2841	5 x 150	M	2091	3171	3253	2503	1429	42	82	150
	PGAS01000I	3178	5 x 200	M	2178	3499	3581	2581	1726	50	82	200
	PGAS01000T	4069	6 x 200	R	2869	4399	4481	3281	2011	56	82	200
	PGAS01000TC4	4517	6 x 200	R	3317	4847	4930	3730	2234	86	82	200
	PGAS01000TC3	5017	6 x 200	R	3817	5347	5430	4230	2557	91	82	200
	PGAS01000TC2	5517	8 x 200	R	3917	5848	5930	4330	2733	97	82	200
PGAS01000TC1	5819	9 x 200	R	4019	6149	6231	4431	2733	102	82	200	
2000	PGAS02000S	2345	5 x 150	M	1595	2675	2757	2007	1212	35	82	150
	PGAS02000M	2841	5 x 150	M	2091	3171	3253	2503	1429	42	82	150
	PGAS02000I	3178	5 x 200	M	2178	3499	3581	2581	1726	50	82	200
	PGAS02000T	4069	6 x 200	R	2869	4399	4481	3281	2011	56	82	200
	PGAS02000TC4	4517	6 x 200	R	3317	4847	4930	3730	2234	86	82	200
	PGAS02000TC3	5017	6 x 200	R	3817	5347	5430	4230	2557	91	82	200
	PGAS02000TC2	5517	8 x 200	R	3917	5848	5930	4330	2733	97	82	200
PGAS02000TC1	5819	9 x 200	R	4019	6149	6231	4431	2733	102	82	200	
3000	PGAS03000S	2400	5 x 150	M	1650	2730	2812	2062	1212	56	82	200
	PGAS03000M	2896	5 x 150	M	2146	3226	3308	2558	1429	61	82	200
	PGAS03000I	3178	5 x 200	R	2178	3499	3581	2581	1726	73	82	200
	PGAS03000T	4069	6 x 200	R	2869	4399	4481	3281	2021	85	82	200
	PGAS03000TC4	4517	6 x 200	R	3317	4847	4930	3730	2234	86	82	200
	PGAS03000TC3	5017	6 x 200	R	3817	5347	5430	4230	2557	91	82	200
	PGAS03000TC2	5517	8 x 200	R	3917	5848	5930	4330	2733	97	82	200
5000	PGAS05000IR	3181	5 x 200	R	2181	3592	3717	2717	1736	99*	125	200
	PGAS05000TR	4049	6 x 200	R	2849	4487	4612	3412	2021	109*	125	200
	PGAS05000TC4R	4500	6 x 200	R	3300	4938	5062	3862	2234	96	125	200
	PGAS05000TC3R	5000	6 x 200	R	3800	5438	5562	4362	2557	101	125	200
S & M versions also available as custom systems   M = Manual & R = Ratchet   WLL 5000kg dimensions systems are shown using the deeper 'D' section beam												
Dimensions use standard Master Link Trolley, other options available to increase resulting height of lift (HoL) and to assist with load movement. *Weight includes stabiliser legs.												

# ▶ PORTAGANTRY Trolley Options

## ▶ Gated Trolley [Patented]

Our Gated Trolley is expertly designed to incorporate a rotating plate and quick release pin for easy and rapid attachment to the beam. This unique and innovative product enables multiple trolleys to be attached to beam after the Gantry has been fully assembled and can also be locked in position on the beam.

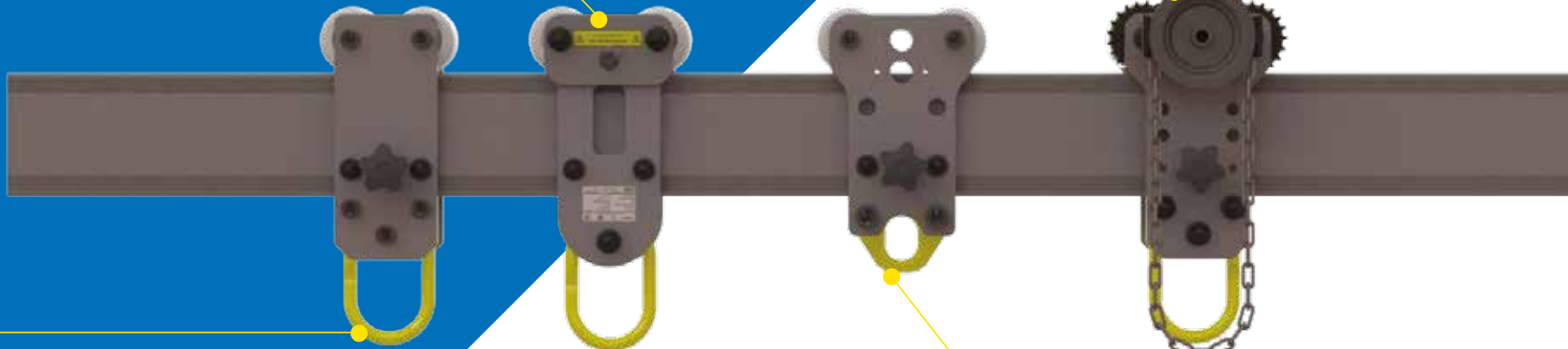

## ▶ Master Link Trolley

The Master Link trolley is fed on to the end of the beam during the assembly of the Gantry. The master link enables a wide range of hoists to be easily attached for lifting operations. The trolley can also be locked in position on the beam.

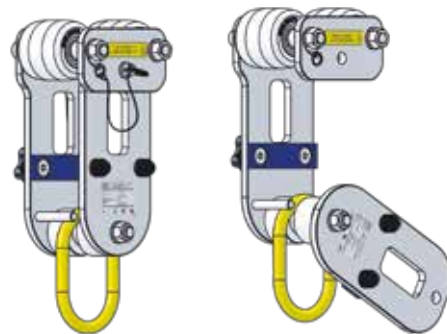

## ▶ Gear Driven Trolley

The Gear Driven Trolley is fed on to the end of the beam during the assembly of the Gantry. It is designed to enable a load up to 2000kg to be moved safely along the beam in a controlled manner once lifted. Different chain lengths are available.

## ▶ Closed Coupled Trolley

Our Closed Coupled Trolley is designed for use where there is a height restriction that requires an incremental increase in the height of lift. The Closed Coupled Trolley is fed on to the beam during the assembly of the Gantry. This trolley can accommodate a wide range of hoists due to its large oval opening and can be locked into position on the beam.

\* The Gated Trolley is tested to and meets the requirements of EN795.2012 and IRATA ICOP for fall protection applications. Each trolley is rated 2500kg for this purpose.



## > Master Link Trolley

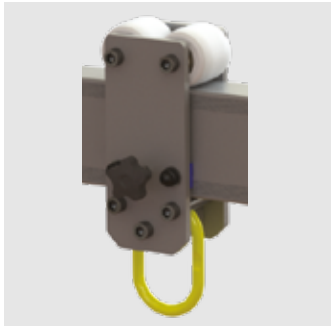

Product Code	Description
PGTZO0500	Master Link Trolley rated up to 500kg to Fit A or B Size Beam
PGTZO1000	Master Link Trolley rated up to 1000kg to Fit A or B Size Beam
PGTZO2000	Master Link Trolley rated up to 2000kg to Fit A or B Size Beam
PGTZO3000	Master Link Trolley rated up to 3000kg to Fit A or B Size Beam
PGTZL02000	Master Link Trolley rated up to 2000kg to Fit D Size Beam
PGTZL03000	Master Link Trolley rated up to 3000kg to Fit D Size Beam
PGTZL05000	Master Link Trolley rated up to 5000kg to Fit D Size Beam

## > Gated Trolley



Product Code	Description
PGTGS00500	Gated Master link Trolley rated up to 500kg to Fit A or B Size Beam
PGTGS01000	Gated Master link Trolley rated up to 1000kg to Fit A or B Size Beam
PGTGS02000	Gated Master link Trolley rated up to 2000kg to Fit A or B Size Beam
PGTGS03000	Gated Master link Trolley rated up to 3000kg to Fit A or B Size Beam

## > Closed Coupled Trolley

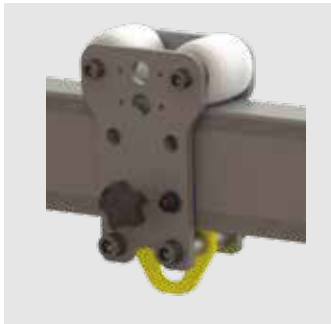

Product Code	Description
PGTXS00500V2	Close Coupled Trolley rated up to 500kg to Fit A or B Size Beam
PGTXS01000V2	Close Coupled Trolley rated up to 1000kg to Fit A or B Size Beam
PGTXS02000V2	Close Coupled Trolley rated up to 2000kg to Fit A or B Size Beam
PGTXS03000V2	Close Coupled Trolley rated up to 3000kg to Fit A or B Size Beam
PGTXL02000V2	Close Coupled Trolley rated up to 2000kg to Fit D Size Beam
PGTXL03000V2	Close Coupled Trolley rated up to 3000kg to Fit D Size Beam

## > Gear Driven Trolley

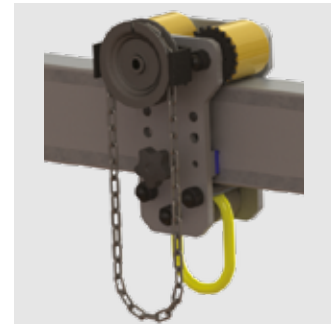

Product Code	Description
PGTYS00500	Gear Driven Trolley rated up to 500kg to Fit A or B Size Beam
PGTYS01000	Gear Driven Trolley rated up to 1000kg to Fit A or B Size Beam
PGTYL02000	Gear Driven Trolley rated up to 2000kg to Fit D Size Beam

\* We offer a range of Geared and Integrated Hoist trollies for more information contact your REID representative.

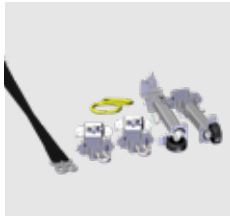

## > Gantry Assembly Aid

The Gantry Assembly Aid has been designed to aid in the ease of erecting and dismantling our **PORTAGANTRY** systems. It is ideally suited to our intermediate and above-height gantries. The Assembly Aid reduces installation time, as well as manual handling requirements.

Product Code	Description
RAPG000200	Assembly Aid Only
RAPG000200 RAPG000201	Snap Hook Strop Kit for Intermediate and Tall Gantry Systems Assembly Aid
RAPG000200 RAPG000202	Snap Hook Strop Kit for TC4 and TC3 Gantry Systems Assembly Aid
RAPG000200 RAPG000203	Snap Hook Strop Kit for TC2 and TC1 Gantry Systems Assembly Aid
RAPG000203	Bag for Assembly Aid Kit



## > Directional Lock Castors

Our Directional Lock Castors allow for our swivel castors to be made into a fixed castor temporarily - by locking the swivel head but not the wheel which means the castor moves in one direction. Directional locking castors are great for cornering or pivoting.

Product Code	Description
RSCA000008	Porta Gantry Directional Lock Castors - up to 3000kg [Set of 1]
RSCA000010	Porta Gantry Directional Lock Castors - up to 5000kg [Set of 1]



## > Trolley Rope Control System

Our Rope Control System allows precise control over the movement of the load trolley from a safe location next to the A-frame. By utilising a series of sheaves and a winch a mechanical advantage is added to the system reducing the effort during operations. This system not only adds a method of controlled movement of the load but also removes the need to manually handle the lifted load increasing the safety of the system.

Product Code	Description
PGRC00001	Rope Control System for use with PG Small with A or B section beam
PGRC00002	Rope Control System for use with PG Small with D section beam
PGRC00003	Rope Control System for use with PG Intermediate with A or B section beam
PGRC00004	Rope Control System for use with PG Intermediate with D section beam
PGRC00005	Rope Control System for use with PG Tall with A or B section beam
PGRC00006	Rope Control System for use with PG Tall with D section beam



## > Wind-up Jack Legs

Our Wind-up Jack Legs offer infinite additional height adjustment up to 250mm. The Wind-up Jack Legs offer independent adjustment for use as a levelling system on uneven ground. The Jack Leg retracts beyond the base of the castors and so does not restrict the movement of the system.

Product Code	Description
PGWS00001U	Porta Gantry Universal Wind Up Jack Leg WLL5000kg Set of 4
PGWS00002U	Porta Gantry Universal Wind Up Jack Leg S&M up to 2000kg Set of 4



### > Shackled Cheek Plates

The shackled cheek plate has an integrated shackle pull point which allows for the attachment of a mechanical aid such as a chain hoist to control the movement of a loaded trolley along the beam. By utilising a chain hoist to connect the trolley to the shackle the effort required to move a load during a lifting operation will be significantly reduced. This enables controlled movement of a load and ensures gantry stability when traversing a load along a beam.

Product Code	Description
RAPG000109	Porta Gantry Cheek Plate & Shackle Pull Point Kit

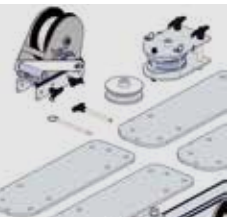

### > Winch Conversion Kit

Our Winch Conversion Kit enables the **PORTAGANTRY** to be used with a wide range of winches or SRLs suitable for goods or personnel lifting. The kit comes with new cheek plates and a winch mounting column to allow for our gantry beams to be prepared to accept a sheave carrier and A-frames a wide range of winches.

Product Code	Description
RAPG000077	Porta Gantry A-frame Conversion Winch Ready Kit



### > Festoon System

Our Festoon System has been designed to keep electric hoist power cords safely away from lifting operations and stored neatly along the gantry beam. The Universal Festoon Kit includes all the required components including; trolleys, wire rope and fasteners. By then adding the power cable the system is ready for use.

Product Code	Description
RAPG000004	Porta Gantry Festoon System and Brackets only [Advise Beam Length]

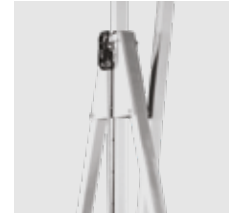

### > Ratchet Height Adjustment

Our Ratchet Height Adjustment provides a mechanical aid for raising and lowering the height of the Gantry beam. The Ratchet Height Adjustment comes as a standard features on a range of A-frames and can be added as a feature on our entire **PORTAGANTRY** product range. See details in dimensions table.

Product Code	Description
RSPG000002	Porta Gantry Tall Ratchet Kit
RSPG000026	Porta Gantry Intermediate Ratchet Kit



### > Lobed Cheek Plates

Our Lobed Cheek Plates allow for ease of assembly when adjusting the operating span of the **PORTAGANTRY** system. The modified cheek plates allows the clear operating span to be adjusted by moving one frame in, whilst still allowing the standard assembly methods to be observed.

Product Code	Description
RSPG000035	Porta Gantry Lobed Cheek Plate up to 5000kg [Each]

# PORTAGANTRY®

Load Bearing Pneumatic Castor Model



This product is patented

Our **PORTAGANTRY**<sup>®</sup> featuring load bearing Pneumatic Castors with air filled tyres offers a quality solution for customers that need to set up and locate their lifting solution on rough terrain, or on roof tops where a standard castor may otherwise cause damage to the surface material. Additionally, the gantry permits movement under load in many scenarios which is made possible by high quality directional locking castors and overall robust gantry design.

### Key features

- Directional locking dual wheel castors with integrated brakes
- Tyres are air filled
- Integrated lifting points and wheel on the frames to support safe raise and lower of the gantry with mechanical advantage
- Integrated shackled cheek plates to enable safe load traversing along the beam
- Integrated ratchet raise and lower system for height adjustment
- Height adjustments at 100mm (4") increments
- Beam adjustment points to enable adjustment of the span to suit site conditions
- Ability to be able to interchange frames for maximum utilisation and freedom to achieve even the most challenging of lifting tasks

### Configurations

The **PORTAGANTRY**<sup>™</sup> featuring load bearing Pneumatic Castors is available in a range of configurations and can be customised in line with specific requirements (subject to WLL rating).

The **PORTAGANTRY**<sup>™</sup> featuring load bearing Pneumatic Castors has the ability to be moved under load. (Subject to detailed instruction and supervision by a competent person).



**2000-3000KG  
WLL**



**1-4 PERSON  
ASSEMBLY**



**92-294KG  
FLAT PACK**

The above features are incorporated in order to ensure maximum utilisation potential of this hybrid gantry solution and therefore maximise return on investment for the user. The gantry will not be rated as a fall protection product and is for material lifting only. For this reason castors cannot be retro-fitted to existing gantry frames.

### Features & Performance

	2000	3000
<b>Capacity</b>		
Maximum Goods Lifting [kg]	2000	3000
<b>Dimensions</b>		
Minimum Height of Lift [mm]	2307	2307
Maximum Height of Lift [mm]	5916	5648
Minimum working Span [mm]	2090	2090
Maximum working Span [mm]	7370	7370
<b>Trolley Options</b>		
Standard	✓	✓
Gated	✓	✓
Close Coupled	✓	✓
Integrated Hoist	✓	✗
<b>Standard Features</b>		
Ratchet Height Adjustment	✓	✓
Mechanical aid Assembly	✓	✓
Shackled cheek plate	✓	✓
Additional height adjustment	✓	✓
<b>Finishes</b>		
Anodised	✓	✓
316SS Fixings	Optional	Optional

Dimensions in the table are approximate values. For more accurate details please refer to the Dimension Table. All line items marked with a '✓' come as standard. All line items marked with a '✗' are not available. All line items marked with 'optional' are available as an option and may incur additional costs.

- A** Beam length
- B** Beam adjustment
- C** Clear operating span
- D** Height to lifting eye
- E** Height increment
- F** Height to top of beam
- G** Width
- H** Height to top of roller

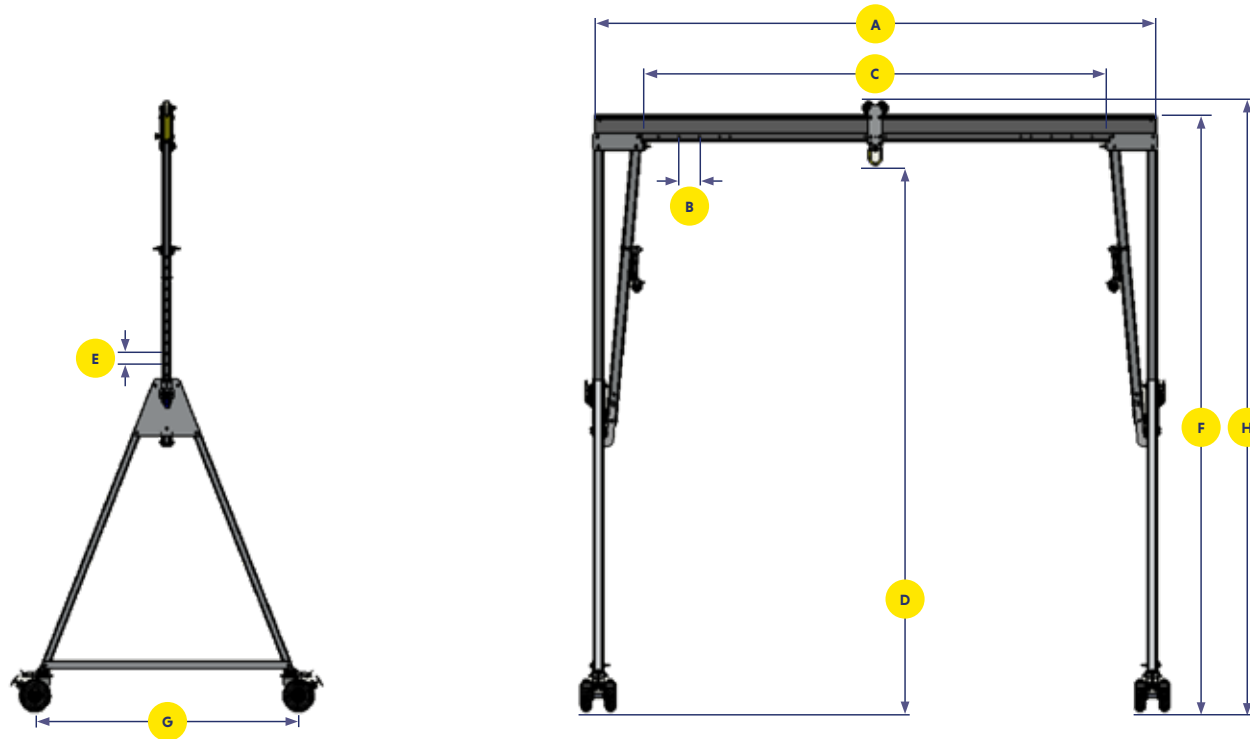

Standard Beam Length A (mm) (Clear Operating Span C = A - 1030 mm)

	3000	3920	4570	5500	6000	8400
<b>A (mm)</b>	3000	3920	4570	5500	6000	8400
<b>C min (mm)</b>	1570	2090	1940	2870	3370	5770
<b>C max (mm)</b>	1970	2890	3540	4470	4970	7370
<b>2000</b>	22	29	34	52	93	130
<b>3000</b>	22	37	43	85	93	130

Weight of Beams [kg]

\*Clear operating span for D section beams is C = A - 1020mm.  
To ensure stability of the structure, the operating span of the beam must be equal to or greater than the distance between the castors on the A-Frame.

Dimensions [mm]

Frame size [Product Code]	Dmax	E	Dmin	Fmax	Hmax	Hmin	G	A frame weight (KG)	Trolley roller size	Castor dimension
	Height to lifting eye	Height increment	Height to lifting eye	Height to top of the beam	Height to top of the roller	Height to top of the roller	Width			
PGAS02000I-PN	3307	10 x 100	2307	3637	3719	2719	2032	94	82	315
PGAS02000TC1-PN	5916	18 x 100	4116	6278	6360	4560	3027	146	82	315
PGAS02000TC3-PN	5113	12 x 100	3913	5476	5558	4358	2851	135	82	315
PGAS02000T-PN	4198	12 x 100	2998	4528	4610	3410	2317	100	82	315
PGAS03000I-PN	3307	12 x 100	2307	3637	3719	2719	2032	117	82	315
PGAS03000TC2-PN	5648	16 x 100	4048	5978	6060	4460	3027	141	82	315
PGAS03000TC3-PN	5113	12 x 100	3913	5476	5558	4358	2851	135	82	315
PGAS03000T-PN	4198	12 x 100	2998	4525	4607	3407	2315	129	82	315

Dimensions use standard Master Link Trolley, other options available to increase resulting height of lift (HoL) and to assist with load movement.

# PORTAGANTRY RAPIDE®

Integrated wheel design that folds with the frame for ease of transportation

Available in 3 height-adjustable versions (up to 2.9m lifting eye height)

Anodised for increased corrosion resistance

Can support goods and personnel lifting

Can accommodate a range of beam lengths up to 4 metres

Engineered designs and bespoke sections reduce weight, providing lightweight portability

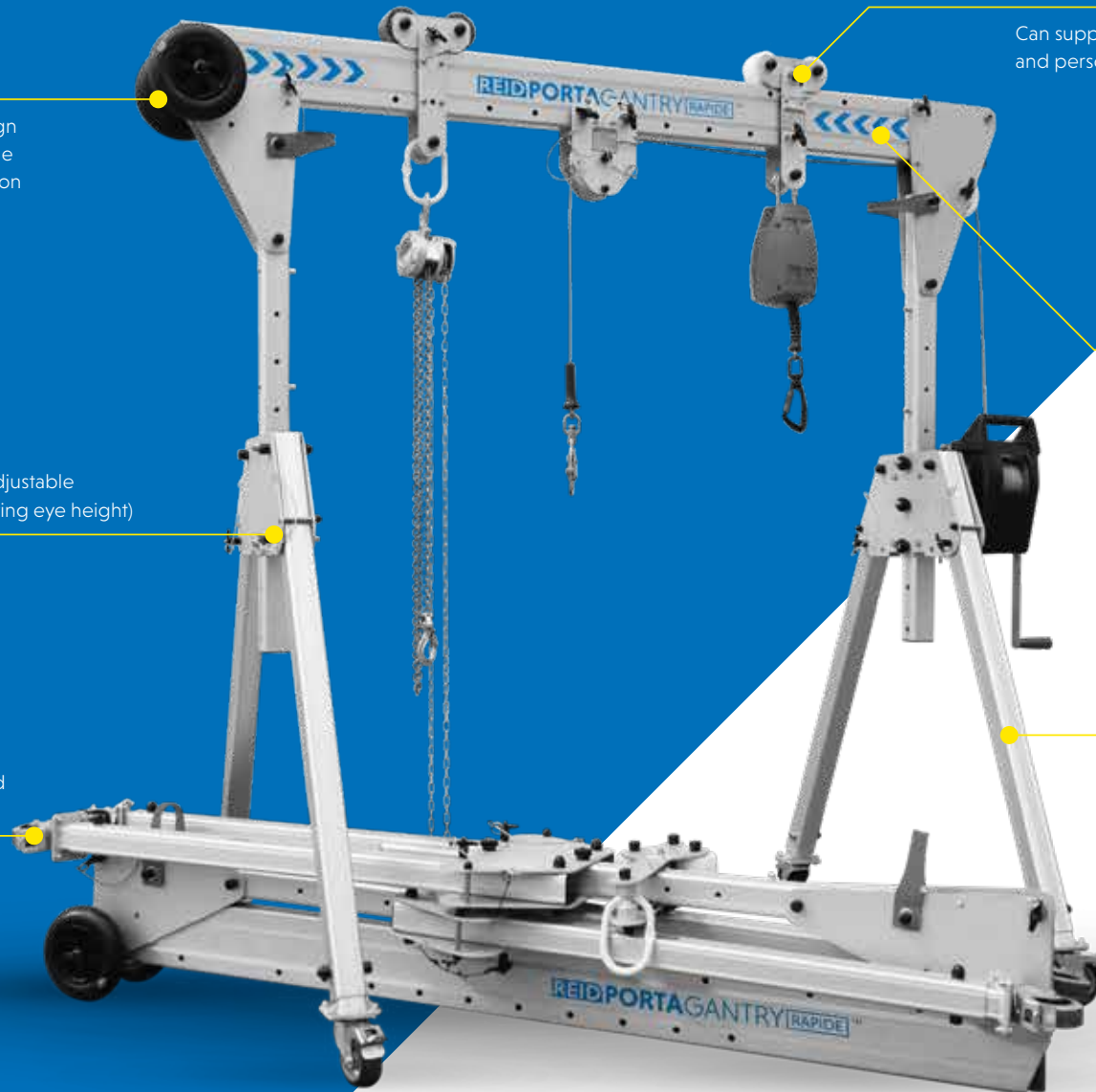

This product is patented

\* Visit our website for our product assembly videos to find out how easy our PORTAGANTRY RAPIDE® range can be assembled in the field.



Our unique and innovative **PORTAGANTRY<sup>RAPIDE</sup>** is a height-adjustable, foldable aluminium gantry designed for rapid deployment. Capable of an impressive WLL of up to 1000kg. This system can be assembled and disassembled by just one person within a minute without the need for any tools. The **PORTAGANTRY<sup>RAPIDE</sup>** is the perfect solution for confined space access scenarios due to its unique features and ability to lift equipment and personnel.

## Key features

- EN795:2012 Certified
- ATEX Certified
- Can support goods and personnel lifting;
  - Goods WLL of up to 1000kg
  - Personnel WLL of up to 500kg
- Suitable for up to 3 persons for fall protection applications
- Integrated wheel design that folds with the frame for ease of transportation
- Available in 3 height-adjustable versions (up to 2.9m to the lifting eye)
- Can accommodate a range of beam lengths up to 4m
- Anodised for increased corrosion resistance
- Engineered designs and bespoke sections reduce weight, providing lightweight portability

## Configurations

The **PORTAGANTRY<sup>RAPIDE</sup>** is available in a range of configurations and can be customised in line with specific requirements (subject to WLL rating).



250-1000KG  
WLL



1-2 PERSON  
ASSEMBLY



37-69KG  
COMPACT  
STORAGE



EN795  
CERTIFIED



ATEX  
CERTIFIED

## Features & Performance

	PGR500	PGR1000
<b>Accreditations, Certifications &amp; Standards</b>		
EN795:2012	✓	✓
PD CEN / TS16415:2013	✓	✓
ANSI Z359.18-17	✓	✓
AS/NZS 5532:2013	✓	✓
ATEX Certified [Zone 2]	✓	✓
ATEX Certified [Zone 1]	x	Optional
IRATA	✓	✓
<b>Capacity</b>		
Maximum Goods Lifting [kg]	500	1000
Maximum Personnel Lifting [kg]	250	500
Fall Arrest [Persons]	3	3
<b>Dimensions</b>		
Minimum Height of Lift (HOL) [mm]	1450	1430
Maximum Height of Lift (HOL) [mm]	2920	2880
<b>Beam Options</b>		
2.0m	✓	✓
2.3m	✓	x
3.0m	x	✓
4.0m	✓	✓
<b>Trolley Options</b>		
Master Link	✓	✓
Close Coupled	✓	✓
Sheave Carrier	✓	✓
<b>Features</b>		
Winch Capable	✓	✓
Foot adjustment [100mm]	✓	✓
Foldable	✓	✓
Transport Wheel	✓	✓
Assembly < 60sec	✓	✓
<b>Finishes</b>		
Anodised	✓	✓
Marine Spec	Optional	Optional

Dimensions in the table are approximate values. For more accurate details please refer to the Dimension Table.  
All line items marked with a '✓' come as standard. All line items marked with a 'x' are not available.  
All line items marked with 'optional' are available as an option and may incur additional costs.

## PORTAGANTRY RAPIDE® 250-500

- A** Beam length
- B** Beam adjustment
- C** Clear operating span
- D** Height to lifting eye
- E** Height increment
- F** Height to top of beam
- G** Width
- H** Height to top of roller
- J** Folding dimensions

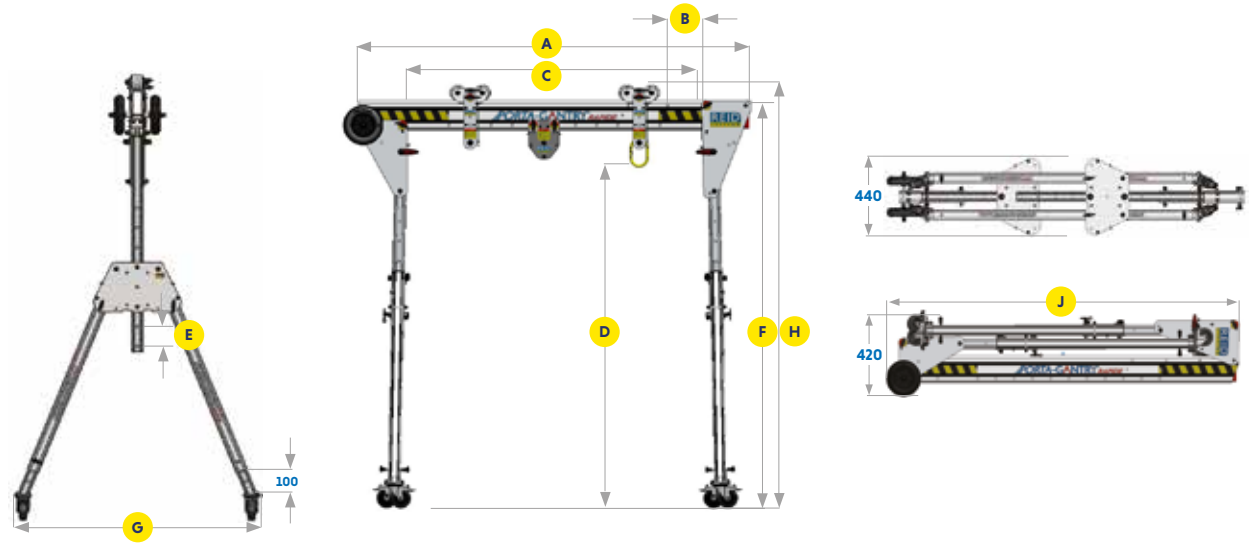

## PORTAGANTRY RAPIDE® 1000

- A** Beam length
- B** Beam adjustment
- C** Clear operating span
- D** Height to lifting eye
- E** Height increment
- F** Height to top of beam
- G** Width
- H** Height to top of roller
- J** Folding dimensions

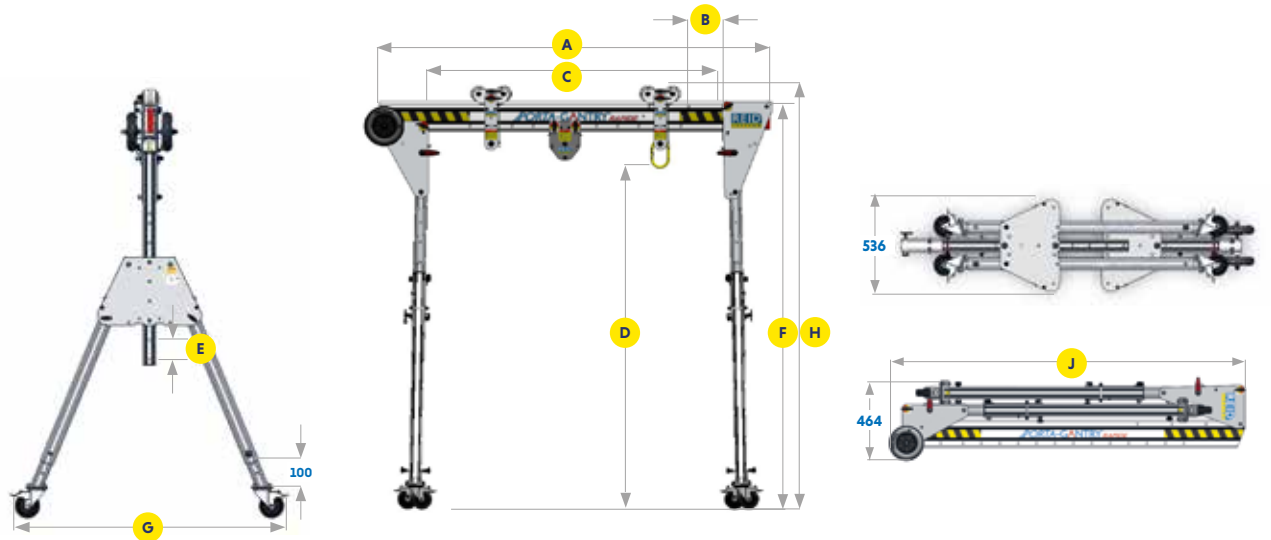

Product Code	Dimensions [mm]												WLL			Unit Weight***		
	A Beam Length	B	CMin	CMax	DMin	DMax	E	FMin	FMax	G	HMin	HMax	J	Goods Capacity [kg]	Fall Arrest Capacity** No of Person(s)	Personnel Positioning** [kg]	[kg]	
PGR	PGRS20	2000	2 x 200	1100	1500	1445	2045	6 x 100	1776	2376	1158	1856	2456	2080	500	3	250	37
	PGRS23	2300	3 x 200	1200	1800									2380	400	2	200	38
	PGRS40	4000	3 x 200	2900	3500									4080	250	1	125	43
	PGRM20	2000	2 x 200	1100	1500	1449	2149	7 x 100	1780	2480	1215	1860	2560	2080	400	2	200	38
	PGRM23	2300	3 x 200	1200	1800									2380				38
	PGRM40	4000	3 x 200	2900	3500									4080	44			
	PVRT20*	2000	2 x 200	665	1065	1923	2923	10 x 100	2254	3254	1586	2334	3334	2645	250	1	125	42
	PVRT23*	2300	3 x 200	765	1365									2380				43
	PVRT40*	4000	3 x 200	2465	3065									4080				48

\*Trolley stops fitted to beam \*\*Ratings using European standards. Contact REID for other standards. \*\*\* Weight includes castor inserts.

Product Code	Dimensions [mm]												WLL			Unit Weight***		
	A Beam Length	B	CMin	CMax	DMin	DMax	E	FMin	FMax	G	HMin	HMax	J	Goods Capacity [kg]	Fall Arrest Capacity** No of Person(s)	Personnel Positioning** [kg]	[kg]	
PGRIT	PGRITS20	2000	2 x 200	1102	1502	1425	1925	5 x 100	1822	2322	1270	1904	2404	2077	1000	3	500	52
	PGRITS30	3000	3 x 200	1902	2502									3077	1000	3	500	57
	PGRITS40	4000	3 x 200	2902	3502									4077	1000	3	500	61
	PGRITM20	2000	2 x 200	1102	1502	1735	2435	7 x 100	2061	2761	1484	2143	2843	2200	1000	3	500	56
	PGRITM30	3000	3 x 200	1902	2502									3077	1000	3	500	60
	PGRITM40	4000	3 x 200	2902	3502									4077	1000	3	500	65
	PGRITT20*	2000	2 x 200	665	1065	1975	2875	9 x 100	2301	3201	1698	2383	3283	2830	1000	3	500	60
	PGRITT30*	3000	3 x 200	1465	2065									3077	1000	3	500	64
	PGRITT40*	4000	3 x 200	2465	3065									4077	1000	3	500	69

\*Trolley stops fitted to beam. \*\*Ratings using European standards. Contact REID for other standards. \*\*\* Weight includes castor inserts.

# ▶ PORTAGANTRY RAPIDE® Accessories

## ▶ Sheave Carrier

Sheave carriers enable the use of winches or retrieval fall arrest devices with the PORTAGANTRY RAPIDE®. They are detachable and can incorporate either one or two pulley wheels to act as guides for cables or ropes.

## ▶ Master Link Trolley

Our Gated [patent pending] Master Link Trolley can be used when additional headroom or clearance is not an issue and the convenience of a large opening for the attachment of various hoists is preferred. This innovative product enables multiple trolleys to be attached to the beam after the system has been fully assembled and can also be locked in position on the beam.

## ▶ Close Coupled Trolley

Our Gated [patent pending] Close Coupled Trolley can be used when additional headroom or clearance is needed below the beam. This trolley can be attached to the beam after the system has been fully assembled.

## ▶ Sheave

Sheaves can be retroactively fitted to the PORTAGANTRY RAPIDE® enabling winches or retrieval fall arrest devices to be attached to the trap plate of vertical column.

## ▶ Winch Bracket

Winch brackets can be attached to the trap plates or to the upright, depending on the winch and its orientation. REID offers a wide range of winch brackets for common goods and personnel winches and retrieval fall arrest devices. Due to the wide range and our ability to manufacture custom brackets, contact us with your requirements.



### > Close Coupled Trolley



Product Code	Description
PGTXR00500	Trolley Close Coupled WLL500kg
PGTXR01000	Trolley Close Coupled WLL1000kg

### > Master Link Trolley



Product Code	Description
PGTZR00500	Trolley Master Link WLL500kg
PGTZR01000	Trolley Master Link WLL1000kg

### > Sheave Carrier



Product Code	Description
PGTTR00501	Double Sheave Carrier up to 500kg
PGTUR00501	Single Sheave Carrier up to 500kg
PGTTR01001	PGR Double Sheave Carrier - WLL500kg
PGTUR01001	PGR Single Sheave Carrier - WLL500kg

### > Sheave



Product Code	Description
RAPGR00032	Rapide Universal Sheave and Ball Lock Pin Set

### > Winch Bracket



We offer a wide range of Winch Brackets, which are designed to support winches for both goods and personnel lifting and retrieval fall arrest devices. Contact REID with your requirements and find out how we can support you.

# > Gantry Accessories



## > Winch Brackets

We offer a wide range of winch brackets for common goods and personnel winches. The winch brackets can be attached to each Gantry to support the application required. Operations & Assembly instructions can be found for each device on our website.



## > SRL Brackets

We offer a range of universal bracket solutions that allow for use of Safety Retrieval Lifeline devices with our Gantry range. Operations & Assembly instructions can be found for each device on our website.

## > Supported Winch & SRL Devices

We support a wide range of devices with our custom brackets to fit our product solutions. For a complete list of all supported devices and solutions, please see page 31.



## Winch & SRL Brackets Part Codes

		PORTAGANTRY <sup>®</sup> RAPIDE <sup>™</sup> 500kg	PORTAGANTRY <sup>®</sup> RAPIDE <sup>™</sup> 1000kg	PORTAGANTRY <sup>®</sup> Small and Medium	PORTAGANTRY <sup>®</sup>
Personnel Winches	<b>G.Winch</b>	RAWB005220	RAWB005220	RAWB005225	RAWB005208
	<b>Guardian Checkmate</b>	RAWB001220	RAWB001220	RAWB001220	RAWB001200
	<b>IKAR PLW</b>	RAWB004220	RAWB004220	RAWB004225	RAWB004200
	<b>MSA Rescuer</b>	RAWB008020	RAWB008020	RAWB008020	RAWB008000
	<b>MSA Workman</b>	RAWB008220	RAWB008220	RAWB008220	RAWB008000
	<b>3M SALA Winch</b>	RAWB003520	RAWB003520	RAWB003522	RAWB003000
	<b>3M DBI SALA Digital Winch</b>	RAWB003520	RAWB003520	RAWB003522	RAWB003000
	<b>Tuffbuilt Pro Series 1</b>	RAWB009220	RAWB009220	RAWB009225	RAWB009200
	<b>Tuffbuilt Pro Series 2</b>	RAWB009320	RAWB009320	RAWB009325	RAWB009300
SRL Devices	<b>Guardian FABXR</b>	RAWB001020	RAWB001020	RAWB001020	RAWB001000
	<b>Tractel Blocfor</b>	RAWB002020	RAWB002020	RAWB002020	RAWB002000
	<b>3M Rebel Protect A</b>	RAWB003520	RAWB003520	RAWB003522	RAWB003000
	<b>3M SALA Sealed Block</b>	RAWB003520	RAWB003520	RAWB003522	RAWB003000
	<b>3M Sala Ultra-Lok</b>	RAWB003525	RAWB003525	RAWB003520	RAWB003000
	<b>IKAR HRA</b>	RAWB004020	RAWB004020	RAWB004020	RAWB004000
	<b>Globestock G-Saver GSE 414G</b>	RAWB005520	RAWB005520	RAWB005520	RAWB005500
	<b>Globestock G-Saver GSE 420G</b>	RAWB005020	RAWB005020	RAWB005020	RAWB005000
	<b>Globestock G-Saver GSE 434G</b>	RAWB005020	RAWB005020	RAWB005020	RAWB005000
	<b>Ridgegear</b>	RAWB006020	RAWB006020	RAWB006020	RAWB006000



# Davit Systems

We offer three different types of Davits and multiple sockets for the widest range of applications, all of which are designed to make light work of lifting and lowering.

- 34** TDAVIT
- 40** TDAVIT TDT
- 44** TDAVIT TDVW
- 48** PORTADAVIT
- 52** PORTADAVIT<sup>QUANTUM</sup>







# > TDAVIT®

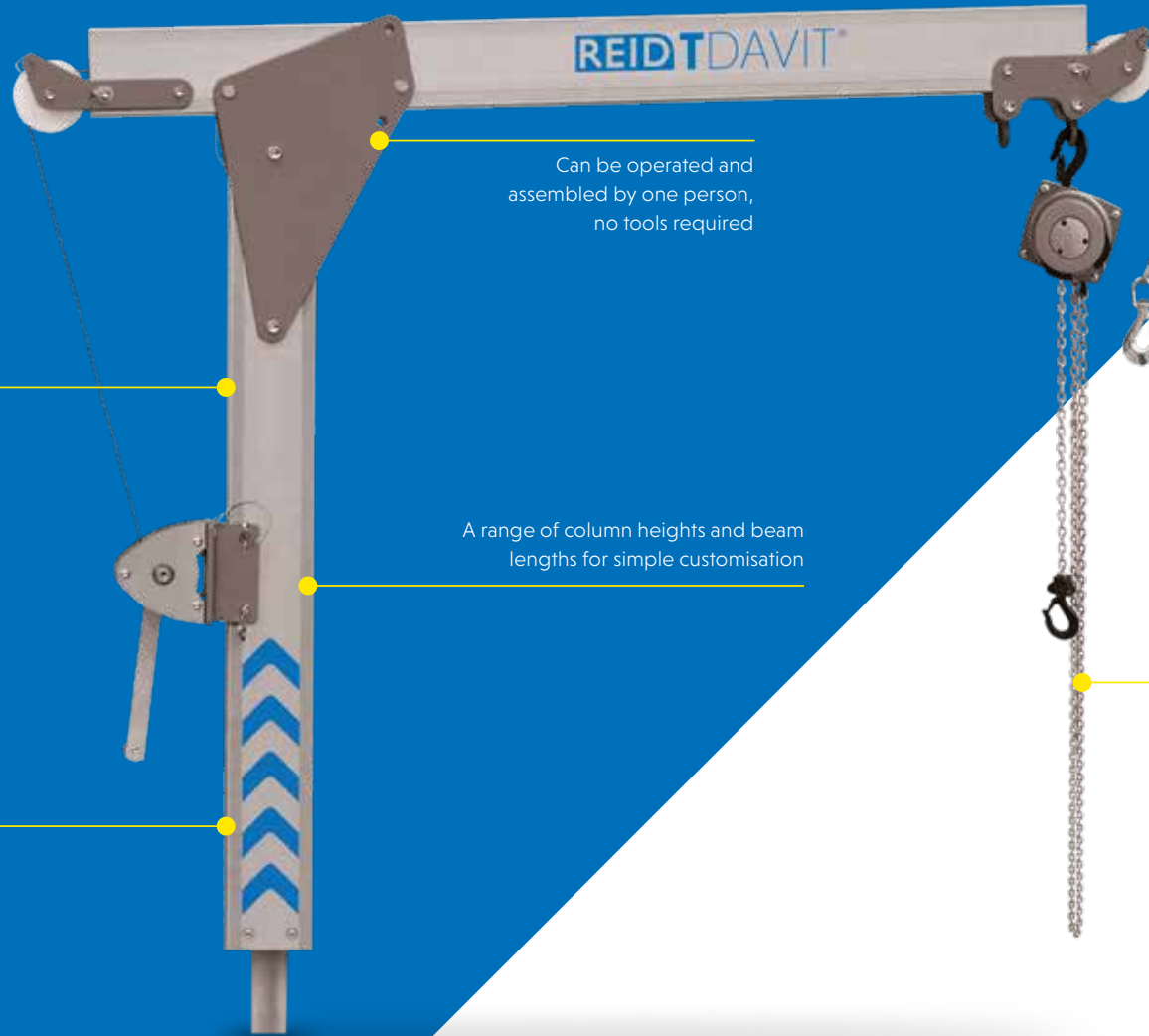

Can be operated and assembled by one person, no tools required

Clean, anodised finish for increased wear resistance

A range of column heights and beam lengths for simple customisation

Capacity of up to 600kg for goods lifting

Can be rotated 360° under a full load

This product is patented

\*See pages 58-77 for our range of fixed sockets and portable bases.

\*\*Winch and hoist sold separately

Our TDAVIT is lightweight, portable, and as well as a wide range of standard sizes can be custom-designed and manufactured to specifically meet our customers' individual needs. Truly pioneering, it offers a lifting capacity of up to 600kg and 360° rotation under a full load.

## Key features

- EN795:2012 Certified
- ATEX Certified
- Can support goods and personnel lifting;
  - Goods WLL of up to 600kg
  - Personnel WLL of up to 300kg
- Can be operated and assembled by one person, no tools required
- Can be rotated 360° under a full load
- Designed with a universal kingpin which is compatible for all REID sockets
- Clean, anodised finish for increased corrosion resistance
- A variety of attachments for a range of applications
- Engineered designs and bespoke sections reduce weight, providing lightweight portability

## Configurations

The TDAVIT is available in a range of configurations and can be customised in line with specific requirements (subject to WLL rating).

\*\*Refer to REID for further guidance



600KG  
WLL



1 PERSON  
ASSEMBLY



CUSTOMISED  
& BAGGED



EN795  
CERTIFIED



ATEX  
CERTIFIED

## Features & Performance

	BEAM 0	BEAM 1	BEAM 2	BEAM 3	BEAM 4
<b>Accreditations, Certifications &amp; Standards</b>					
EN795:2012	✓	✓	✓	✓	✗
AS/NZS 5532:2013	✓	✓	✓	✓	✗
ATEX Certified [Zone 2]	✓	✓	✓	✓	✓
ATEX Certified [Zone 1]	Optional	Optional	Optional	Optional	Optional
IRATA	✓	✓	✓	✓	✗
<b>Capacity</b>					
Maximum Goods Lifting [kg]	600	500	500	375	300
Maximum Personnel Lifting [kg]	300	250	250	150	✗
Fall Arrest [Persons]	1	1	1	1	✗
<b>Dimensions</b>					
Maximum Reach [mm]	800	1000	1200	1600	2000
Maximum Height of Lift [mm]	2165	2240	2315	2460	2615
<b>Socket Diameter</b>					
65mm	✓	✓	✓	✓	✓
<b>Socket Options</b>					
Top Mount	✓	✓	✓	✓	✓
Flush Mount	✓	✓	✓	✓	✓
Side Mount	✓	✓	✓	✓	✓
Bridge Mount	✓	✓	✓	✓	✓
Pedestal	✓	✓	✓	✓	✓
Extension Post	✓	✓	✓	✓	✓
<b>Standard Features</b>					
Shackle Lifting points	✓	✓	✓	✓	✓
Component Weight < 25kg	✓	✓	✓	✓	✓
<b>Optional Extras</b>					
Winch Capable	✓	✓	✓	✓	✓
Rotational Handle	✓	✓	✓	✓	✓
<b>Finishes</b>					
Anodised	✓	✓	✓	✓	✓
316SS Fixings	Optional	Optional	Optional	Optional	Optional
Marine Spec	Optional	Optional	Optional	Optional	Optional

Dimensions in the table are approximate values. For more accurate details please refer to the Dimension Table.  
All line items marked with a '✓' come as standard. All line items marked with a '✗' are not available.  
All line items marked with 'optional' are available as an option and may incur additional costs.

## TDAVIT® WINCHED

- A** Radius | Position A
- B** Radius | Position B
- C** Height of Lift | Position A
- D** Height of Lift | Position B
- W1** Winch Position 1
- W2** Winch Position 2
- W3** Winch Position 3
- W4** Winch Position 4
- W5** Winch Position 5
- P1** Height of Pin Position 1
- P2** Height of Pin Position 2

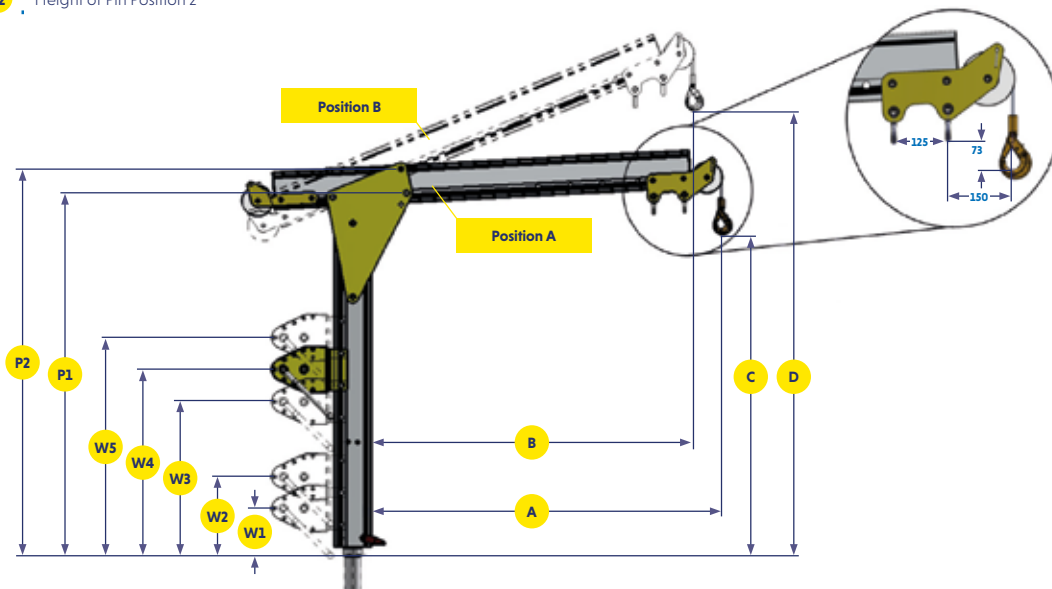

Product Code	Description
TDWA1A0TD2	T-Davit Type W Column option 1 Beam option 0 WLL 600kg
TDWA1A1TD2	T-Davit Type W Column option 1 Beam option 1 WLL 500kg
TDWA1A2TD2	T-Davit Type W Column option 1 Beam option 2 WLL 500kg
TDWA1A3TD2	T-Davit Type W Column option 1 Beam option 3 WLL 375kg
TDWA1A4TD2	T-Davit Type W Column option 1 Beam option 4 WLL 300kg
TDWA2A0TD2	T-Davit Type W Column option 2 Beam option 0 WLL 600kg
TDWA2A1TD2	T-Davit Type W Column option 2 Beam option 1 WLL 500kg
TDWA2A2TD2	T-Davit Type W Column option 2 Beam option 2 WLL 500kg
TDWA2A3TD2	T-Davit Type W Column option 2 Beam option 3 WLL 375kg
TDWA2A4TD2	T-Davit Type W Column option 2 Beam option 4 WLL 300kg
TDWA3A0TD2	T-Davit Type W Column option 3 Beam option 0 WLL 600kg
TDWA3A1TD2	T-Davit Type W Column option 3 Beam option 1 WLL 500kg
TDWA3A2TD2	T-Davit Type W Column option 3 Beam option 2 WLL 500kg
TDWA3A3TD2	T-Davit Type W Column option 3 Beam option 3 WLL 375kg
TDWA3A4TD2	T-Davit Type W Column option 3 Beam option 4 WLL 300kg
TDWA4A0TD2	T-Davit Type W Column option 4 Beam option 0 WLL 600kg
TDWA4A1TD2	T-Davit Type W Column option 4 Beam option 1 WLL 500kg
TDWA4A2TD2	T-Davit Type W Column option 4 Beam option 2 WLL 500kg
TDWA4A3TD2	T-Davit Type W Column option 4 Beam option 3 WLL 375kg
TDWA4A4TD2	T-Davit Type W Column option 4 Beam option 4 WLL 300kg
TDWA5A0TD2	T-Davit Type W Column option 5 Beam option 0 WLL 600kg
TDWA5A1TD2	T-Davit Type W Column option 5 Beam option 1 WLL 500kg
TDWA5A2TD2	T-Davit Type W Column option 5 Beam option 2 WLL 500kg
TDWA5A3TD2	T-Davit Type W Column option 5 Beam option 3 WLL 375kg
TDWA5A4TD2	T-Davit Type W Column option 5 Beam option 4 WLL 300kg

## ➤ How To Specify A TDAVIT

Select a beam option from the table based on the radius you require. Each TDAVIT has two radius options A or B which is determined by the beam position [refer to the dimensional drawing on page 36].

Be aware that larger radius beams reduce the working load limit of the TDAVIT.

Select your column option from the dimensional table based on the height of lift you require. Column option 1 is our shortest standard column and option 5 is our tallest.

Should you need a greater height of lift, you can add a pedestal or socket extension, subject to restrictions [see 74-77 for further information].

For our standard TDAVIT product codes refer to the product code list on page 36 for any custom requests please contact your REID representative.

To request a quote and any additional information on sockets or accessories such as winches and chain hoists, contact your local reseller or your REID representative. See our accessories on pages 56-57.

		0		1		2		3		4						
		A	B	A	B	A	B	A	B	A	B					
		800	740	1000	925	1200	1110	1600	1485	2000	1855					
		600		500		500		375		300						
		11.5		12		13		16		19						
		C	D	C	D	C	D	C	D	C	D					
Column Option	1	800	1050	810	1125	820	1200	840	1345	860	1500	20	W1	220	P1	P2
													W2	320	980	1080
	2	980	1230	990	1305	1000	1380	1020	1525	1040	1680	21	W1	220	1165	1265
													W2	320		
													W3	675		
3	1290	1540	1300	1615	1310	1690	1330	1835	1350	1990	23	W1	220	1475	1575	
												W2	320			
												W3	675			
												W4	775			
												W5	875			
4	1605	1855	1615	1930	1625	2005	1645	2150	1665	2305	25	W3	675	1790	1890	
												W4	775			
												W5	875			
5	1915	2165	1925	2240	1935	2315	1955	2460	1975	2615	28	W5	875	2100	2200	

\*Radii achieved at =75% WLL

## TDAVIT® SHACKLED

- A** Radius | Position A
- B** Radius | Position B
- C** Height of Lift | Position A
- D** Height of Lift | Position B
- P1** Height of Pin Position 1
- P2** Height of Pin Position 2

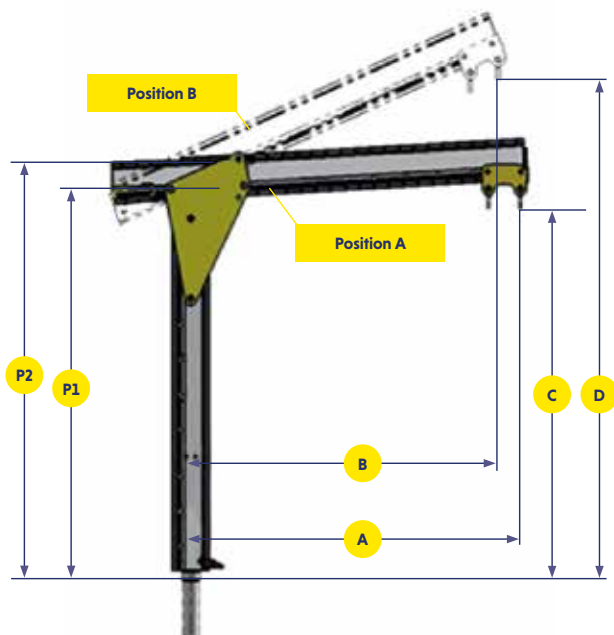

Product Code	Description
TDSA1A0TD2	T-Davit Type S Column option 1 Beam option 0 WLL 600kg
TDSA1A1TD2	T-Davit Type S Column option 1 Beam option 1 WLL 500kg
TDSA1A2TD2	T-Davit Type S Column option 1 Beam option 2 WLL 500kg
TDSA1A3TD2	T-Davit Type S Column option 1 Beam option 3 WLL 375kg
TDSA1A4TD2	T-Davit Type S Column option 1 Beam option 4 WLL 300kg
TDSA2A0TD2	T-Davit Type S Column option 2 Beam option 0 WLL 600kg
TDSA2A1TD2	T-Davit Type S Column option 2 Beam option 1 WLL 500kg
TDSA2A2TD2	T-Davit Type S Column option 2 Beam option 2 WLL 500kg
TDSA2A3TD2	T-Davit Type S Column option 2 Beam option 3 WLL 375kg
TDSA2A4TD2	T-Davit Type S Column option 2 Beam option 4 WLL 300kg
TDSA3A0TD2	T-Davit Type S Column option 3 Beam option 0 WLL 600kg
TDSA3A1TD2	T-Davit Type S Column option 3 Beam option 1 WLL 500kg
TDSA3A2TD2	T-Davit Type S Column option 3 Beam option 2 WLL 500kg
TDSA3A3TD2	T-Davit Type S Column option 3 Beam option 3 WLL 375kg
TDSA3A4TD2	T-Davit Type S Column option 3 Beam option 4 WLL 300kg
TDSA4A0TD2	T-Davit Type S Column option 4 Beam option 0 WLL 600kg
TDSA4A1TD2	T-Davit Type S Column option 4 Beam option 1 WLL 500kg
TDSA4A2TD2	T-Davit Type S Column option 4 Beam option 2 WLL 500kg
TDSA4A3TD2	T-Davit Type S Column option 4 Beam option 3 WLL 375kg
TDSA4A4TD2	T-Davit Type S Column option 4 Beam option 4 WLL 300kg
TDSA5A0TD2	T-Davit Type S Column option 5 Beam option 0 WLL 600kg
TDSA5A1TD2	T-Davit Type S Column option 5 Beam option 1 WLL 500kg
TDSA5A2TD2	T-Davit Type S Column option 5 Beam option 2 WLL 500kg
TDSA5A3TD2	T-Davit Type S Column option 5 Beam option 3 WLL 375kg
TDSA5A4TD2	T-Davit Type S Column option 5 Beam option 4 WLL 300kg

## ➤ How To Specify A TDAVIT

Select a beam option from the table based on the radius you require. Each TDAVIT has two radius options A or B which is determined by the beam position [refer to the dimensional drawing on page 38].

Be aware that larger radius beams reduce the working load limit of the TDAVIT.

Select your column option from the dimensional table based on the height of lift you require. Column option 1 is our shortest standard column and option 5 is our tallest.

Should you need a greater height of lift, you can add a pedestal or socket extension, subject to restrictions [see page 74-77 for further information].

For our standard TDAVIT product codes refer to the product code list on page 38 for any custom requests please contact your REID representative.

To request a quote and any additional information on sockets or accessories such as winches and chain hoists, contact your local reseller or your REID representative. See our accessories on pages 56-57.

		0		1		2		3		4				
		A	B	A	B	A	B	A	B	A	B			
		650	590	850	775	1050	960	1450	1335	1850	1705			
		600		500		500		375		300				
		9		10		11		14		17				
		C	D	C	D	C	D	C	D	C	D	P1	P2	
Column Option	1	880	1100	890	1175	900	1250	920	1395	940	1550	20	980	1080
	2	1060	1280	1070	1355	1080	1430	1100	1575	1120	1730	21	1165	1265
	3	1370	1590	1380	1665	1390	1740	1410	1885	1430	2040	23	1475	1575
	4	1685	1905	1695	1980	1705	2055	1725	2200	1745	2355	25	1790	1890
	5	1995	2215	2005	2290	2015	2365	2035	2510	2055	2665	28	2100	2200

\*Radii achieved at ≈ 75% WLL

# > TDAVIT® TDT

Can be operated and assembled by one person, no tools required

Clean, anodized finish for increased corrosion resistance

A range of column heights and beam lengths for a variety of work environments

Can be rotated 360° under a full load

Integrated geared trolley which improves lateral movement of high capacity loads



The **TDT** can be combined with many proprietary manual hand chain hoists. Suitable hoists are available from REID Lifting and can be combined with the product to provide a holistic lifting solution or can be purchased via our network of resellers operating in your area.

This product is patented

\*See pages 58-77 for our range of fixed sockets and portable bases.



Our TDAVIT – TDT is lightweight, portable and has been designed to meet customer needs where the lifting and moving of equipment in tight spaces is a challenge.

## Key features

- A range of 3 column and 4 beam sizes to suit customer specific needs
- Variable beam traversing via integrated geared trolley and customers choice of hoist
- Trolley can be secured during lift
- Trolley can be traversed whilst under load (34¾" to 45¾" of movement)
- Rotation under load due to patented integral bearing system
- Universal kingpin fits all REID sockets
- Manufactured from marine grade alloy and anodized/powder coated for increased corrosion resistance
- Quality engineering and production parts reduce weight and provide high strength to weight ratios
- Two piece design to reduce manual handling concerns during transportation and assembly
- ATEX Zone 2 (explosive atmospheres) certification as standard
- ATEX Zone 1 (explosive atmospheres) as optional upgrade
- Can be assembled and operated by one person. No tools required

## Configurations

The TDT is available in several standard configurations to meet with customers most common requirements. Custom solutions can be offered by request, subject to the working load limit requirements.

## Features & Performance

	1200	1500	1700	2000
<b>Accreditations, Certifications &amp; Standards</b>				
Directive 2006/42/EC	✓	✓	✓	✓
ATEX Certified [Zone 1]	Optional	Optional	Optional	Optional
<b>Capacity</b>				
Max Goods Lifting (kg)	400	200	150	150
<b>Dimensions</b>				
Maximum Reach (mm)	1200	1500	1700	2000
Maximum Height of Lift (mm)	1945	1960	1971	1986
<b>Socket Diameter</b>				
65mm	✓	✓	✓	✓
<b>Socket Options</b>				
Top Mount	✓	✓	✓	✓
Flush Mount	✓	✓	✓	✓
Side Mount	✓	✓	✓	✓
Bridge Mount	✓	✓	✓	✓
Pedestal	✓	✓	✓	✓
<b>Standard Features</b>				
Component Weight < 25kg	✓	✓	✓	✓
Geared Trolley	✓	✓	✓	✓
<b>Finishes</b>				
Anodised	✓	✓	✓	✓
316SS Fixings	Optional	Optional	Optional	Optional
Marine Spec	Optional	Optional	Optional	Optional

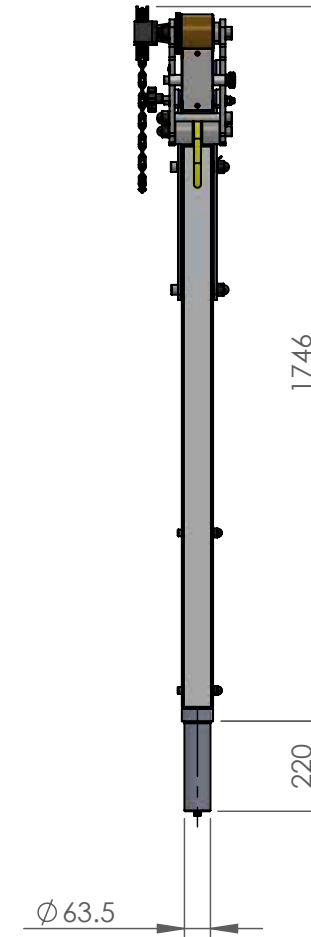
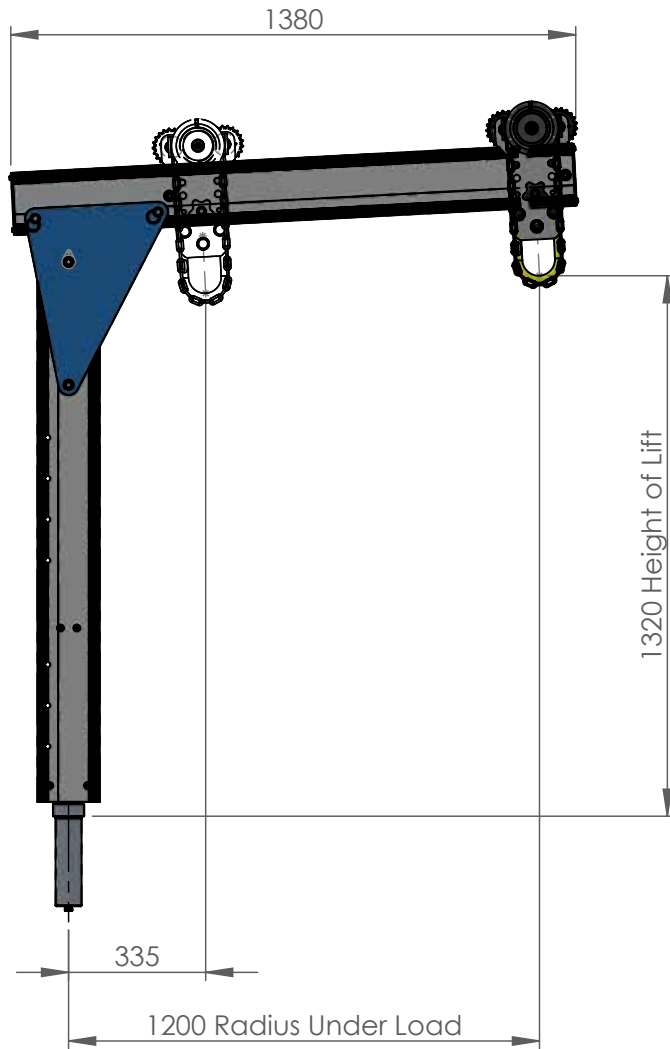

Below is a list of standard **TDT** variants, available from stock. Custom sizes are available if required, subject to limitations. For more information, please email our team at: [enquiries@reidlifting.com](mailto:enquiries@reidlifting.com)

## ➤ Part Numbers and Key Metrics

Part Number	Description	≈ effort on handchain to move trolley under load	Max WLL (Capacity) kg	Overall Davit Height (from Top of Socket) mm	"Max Height of Lift mm"	"Overall Beam Length mm"	"Max Radius mm"	"Max Radius mm"	"Range of Trolley Travel mm"
<b>TDTA51200</b>	T-Davit Type T Column 5 Radius 1200mm WLL400kg	10-15 kg	400	2371	1945	1380	1200	335	865
<b>TDTA51500</b>	T-Davit Type T Column 5 Radius 1500mm WLL400kg	10-15 kg	400	2385	1960	1658	1500	335	1165
<b>TDTA51700</b>	T-Davit Type T Column 5 Radius 1700mm WLL200kg	5-10kg	200	2397	1971	1875	1700	335	1365
<b>TDTA52000</b>	T-Davit Type T Column 5 Radius 2000mm WLL200kg	5-10kg	200	2412	1986	2157	2000	335	1665

<b>TDTA41200</b>	T-Davit Type T Column 4 Radius 1200mm WLL400kg	10-15 kg	400	2061	1635	1380	1200	335	865
<b>TDTA41500</b>	T-Davit Type T Column 4 Radius 1500mm WLL400kg	10-15 kg	400	2075	1650	1658	1500	335	1165
<b>TDTA41700</b>	T-Davit Type T Column 4 Radius 1700mm WLL200kg	5-10kg	200	2087	1661	1875	1700	335	1365
<b>TDTA42000</b>	T-Davit Type T Column 4 Radius 2000mm WLL200kg	5-10kg	200	2102	1676	2157	2000	335	1665

<b>TDTA31200</b>	T-Davit Type T Column 3 Radius 1200mm WLL400kg	10-15 kg	400	1746	1320	1380	1200	335	865
<b>TDTA31500</b>	T-Davit Type T Column 3 Radius 1500mm WLL400kg	10-15 kg	400	1760	1335	1658	1500	335	1165
<b>TDTA31700</b>	T-Davit Type T Column 3 Radius 1700mm WLL200kg	5-10kg	200	1772	1346	1875	1700	335	1365
<b>TDTA32000</b>	T-Davit Type T Column 3 Radius 2000mm WLL200kg	5-10kg	200	1787	1361	2157	2000	335	1665

# > TDAVIT® TDVW

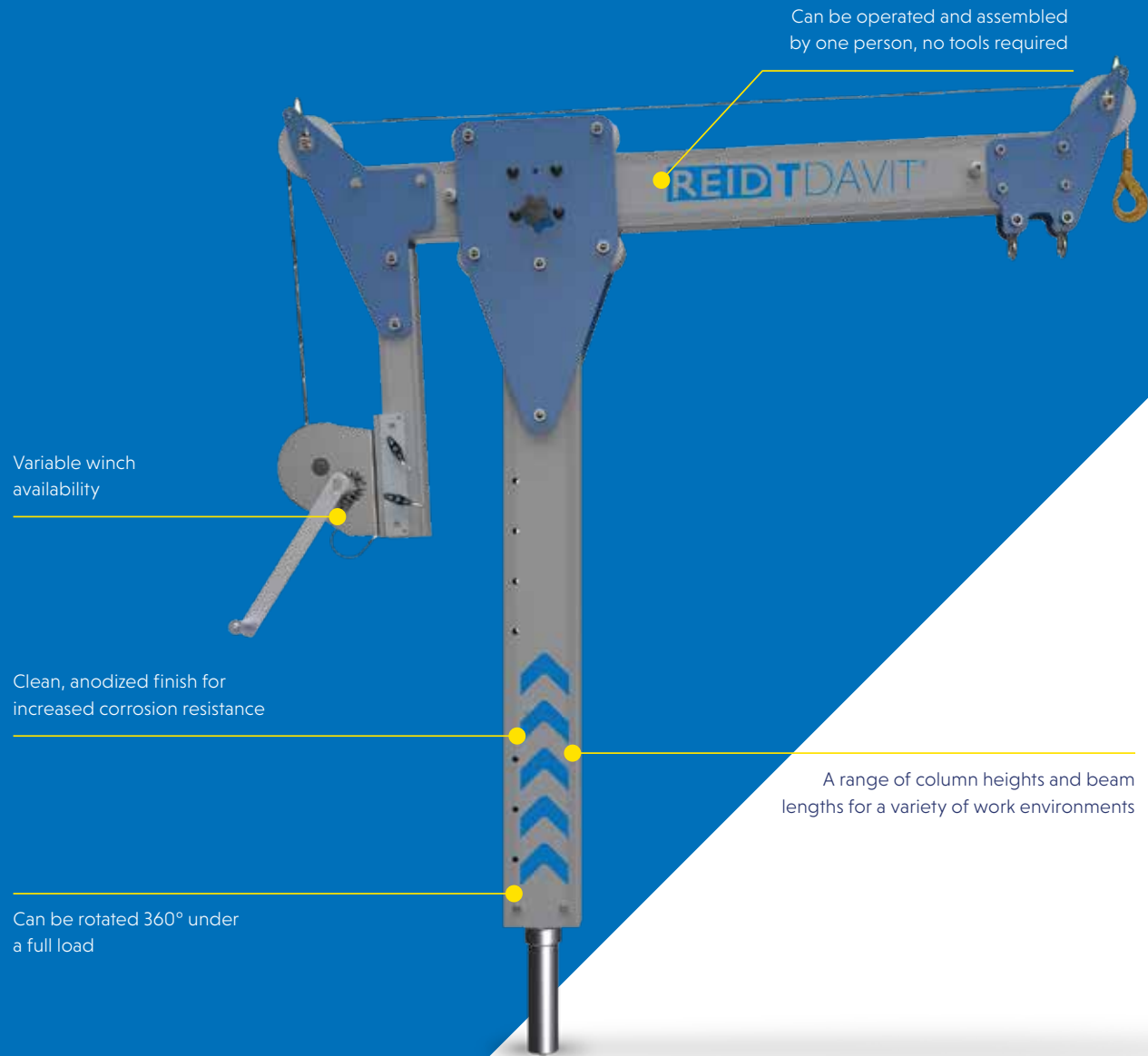

This product is patented

\*See pages 58-77 for our range of fixed sockets and portable bases.

Our **TDAVIT – TDVW** is lightweight, portable and has been designed to meet customer needs where the lifting and moving of equipment in tight spaces is a challenge.

## ➤ Key features

- A range of 3 columns and 4 beam sizes to suit customer specific needs
- Variable beam length achieved with simple manual operation
- Beam can be secured during lift
- Easy beam adjustment whilst under load (726mm to 1526mm of movement)
- Rotation under load due to patented integral bearing system
- Universal kingpin fits all REID sockets
- Manufactured from marine grade alloy and anodised/powder coated for increased corrosion resistance
- Quality engineering and production parts reduce weight and provide high strength to weight ratios
- Two piece design to reduce manual handling concerns during transportation and assembly
- ATEX Zone 2 (explosive atmospheres) certification as standard
- ATEX Zone 1 (explosive atmospheres) as optional upgrade
- Can be assembled and operated by one person. No tools required

## ➤ Configurations

The **TDVW** is available in several standard configurations to meet with customers most common requirements. Custom solutions can be offered by request, subject to the working load limit requirements.

## ➤ Winches

The **TDVW** is compatible with a number of goods winches which are available to purchase directly from REID, or alternatively these can be purchased via our network of resellers operating in your area.

## ➤ Features & Performance

	1200	1500	1700	2000
<b>Accreditations, Certifications &amp; Standards</b>				
Directive 2006/42/EC	✓	✓	✓	✓
ATEX Certified [Zone 1]	Optional	Optional	Optional	Optional
<b>Capacity</b>				
Max Goods Lifting (kg)	300	150	200	200
<b>Dimensions</b>				
Maximum Reach (mm)	1200	1500	1700	2000
Maximum Height of Lift (mm)	2093	2107	2118	2132
<b>Socket Diameter</b>				
65mm	✓	✓	✓	✓
<b>Socket Options</b>				
Top Mount	✓	✓	✓	✓
Flush Mount	✓	✓	✓	✓
Side Mount	✓	✓	✓	✓
Bridge Mount	✓	✓	✓	✓
Pedestal	✓	✓	✓	✓
<b>Standard Features</b>				
Shackle Lifting points	✓	✓	✓	✓
<b>Finishes</b>				
Anodised	✓	✓	✓	✓
316SS Fixings	Optional	Optional	Optional	Optional
Marine Spec	Optional	Optional	Optional	Optional

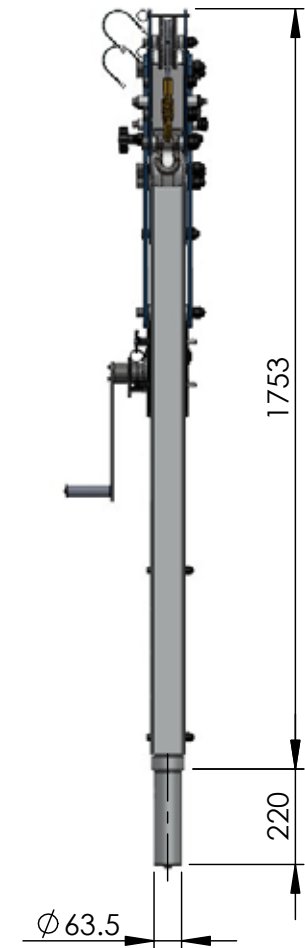
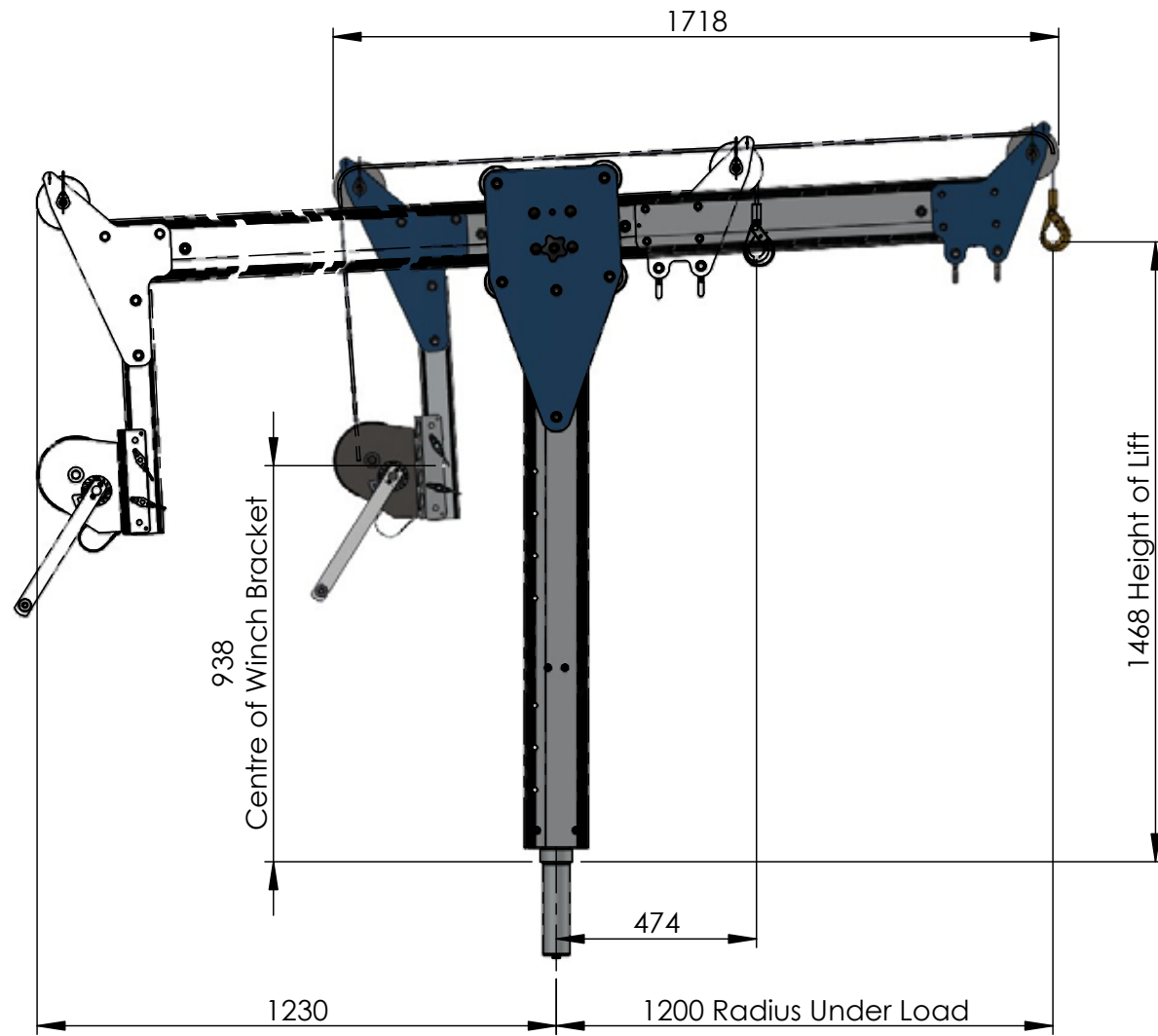

Below is a list of standard **TDVW** variants, available from stock.  
 Custom sizes are available if required, subject to limitations. For more information, please email our team at: [enquiries@reidlifting.com](mailto:enquiries@reidlifting.com)

## ➤ Part Numbers and Key Metrics

Part Number	Description	≈ effort to move beam under load	Max WLL (Capacity) kg	Overall Davit Height (from Top of Socket) mm	Max Height of Lift mm	Overall Beam Length mm	Max Radius mm	Min Radius mm	Range of Beam Travel mm	Clearance required for max beam travel mm
<b>TDVWA51200</b>	T-Davit Type VW Column 5 Radius 1200mm WLL300kg	25-30kg	300	2378	2093	1718	1200	474	726	1230
<b>TDVWA51500</b>	T-Davit Type VW Column 5 Radius 1500mm WLL300kg	25-30kg	300	2392	2107	1991	1500	474	1026	1503
<b>TDVWA51700</b>	T-Davit Type VW Column 5 Radius 1700mm WLL150kg	20-25kg	150	2403	2118	2209	1700	474	1226	1721
<b>TDVWA52000</b>	T-Davit Type VW Column 5 Radius 2000mm WLL150kg	20-25kg	150	2417	2132	2483	2000	474	1526	1995

<b>TDVWA41200</b>	T-Davit Type VW Column 4 Radius 1200mm WLL300kg	25-30kg	300	2068	1783	1718	1200	474	726	1230
<b>TDVWA41500</b>	T-Davit Type VW Column 4 Radius 1500mm WLL300kg	25-30kg	300	2082	1797	1991	1500	474	1026	1503
<b>TDVWA41700</b>	T-Davit Type VW Column 4 Radius 1700mm WLL150kg	20-25kg	150	2093	1808	2209	1700	474	1226	1721
<b>TDVWA42000</b>	T-Davit Type VW Column 4 Radius 2000mm WLL150kg	20-25kg	150	2107	1822	2483	2000	474	1526	1995

<b>TDVWA31200</b>	T-Davit Type VW Column 3 Radius 1200mm WLL300kg	25-30kg	300	1753	1468	1718	1200	474	726	1230
<b>TDVWA31500</b>	T-Davit Type VW Column 3 Radius 1500mm WLL300kg	25-30kg	300	1767	1482	1991	1500	474	1026	1503
<b>TDVWA31700</b>	T-Davit Type VW Column 3 Radius 1700mm WLL150kg	20-25kg	150	1778	1493	2209	1700	474	1226	1721
<b>TDVWA32000</b>	T-Davit Type VW Column 3 Radius 2000mm WLL150kg	20-25kg	150	1792	1507	2483	2000	474	1526	1995

Kingpin height - 220mm. Diameter 63.5mm.

# ▶ PORTADAVIT®

Can be rotated 360° under a full load

Clean powder-coated finish for increased wear resistance

Can be operated and assembled by one person, no tools required

Incredibly lightweight – it weighs just 24kg

This product is patented

\*See pages 58-77 for our range of fixed sockets and portable bases.





Our **PORTADAVIT** is a rapid deployable, lightweight solution that offers a WLL of up to 1000kg and can be easily rotated 360° under a full load. The system can be operated by just one person and can support both goods and personnel lifting.

## Key features

- EN795:2012 Certified
- ATEX Certified
- Can support goods and personnel lifting;
  - Goods WLL of up to 1000kg
  - Personnel WLL of up to 300kg
- Ease of assembly with the use of just one pin, no tools required
- Can be rotated 360° under a full load
- Engineered with easy radius adjustment
- Engineered designs and bespoke sections reduce weight, providing lightweight portability

## Configurations

The **PORTADAVIT** is available in a range of standard configurations. It can also be customised in line with specific requirements and interchangeable components (subject to WLL rating).



## Features & Performance

	500	1000
<b>Accreditations, Certifications &amp; Standards</b>		
EN795:2012	✓	✓
PD CEN / TS16415:2013	x	✓
AS/NZS 5532:2013	✓	✓
ATEX Certified [Zone 2]	✓	✓
ATEX Certified [Zone 1]	Optional	Optional
IRATA	x	✓
<b>Capacity</b>		
Maximum Goods Lifting [kg]	500	1000
Maximum Personnel Lifting [kg]	250	300
Fall Arrest [Persons]	1	2
<b>Dimensions</b>		
Maximum Reach [mm]	1200	1200
Maximum Height of Lift [mm]	2107	2100
<b>Socket Diameter</b>		
65mm	✓	x
95mm	x	✓
<b>Socket Options</b>		
Top Mount	✓	✓
Flush Mount	✓	✓
Side Mount	✓	✓
Bridge Mount	✓	x
Pedestal	✓	x
Extension Post	✓	x
<b>Standard Features</b>		
Shackle Lifting points	✓	✓
Weight < 25kg	✓	x
<b>Optional Extras</b>		
Winch Capable	Optional	x
<b>Finishes</b>		
Anodised	x	✓
Powder Coated	✓	x
316SS Fixings	Optional	Optional
Marine Spec	Optional	Optional

Dimensions in the table are approximate values. For more accurate details please refer to the Dimension Table.  
 All line items marked with a '✓' come as standard. All line items marked with a 'x' are not available.  
 All line items marked with 'optional' are available as an option and may incur additional costs.

**PORTADAVIT® 500**

- A** Overall height from top of socket
- B** Height to outer shackle
- C** Radius to outer shackle
- D** Radius to inner shackle

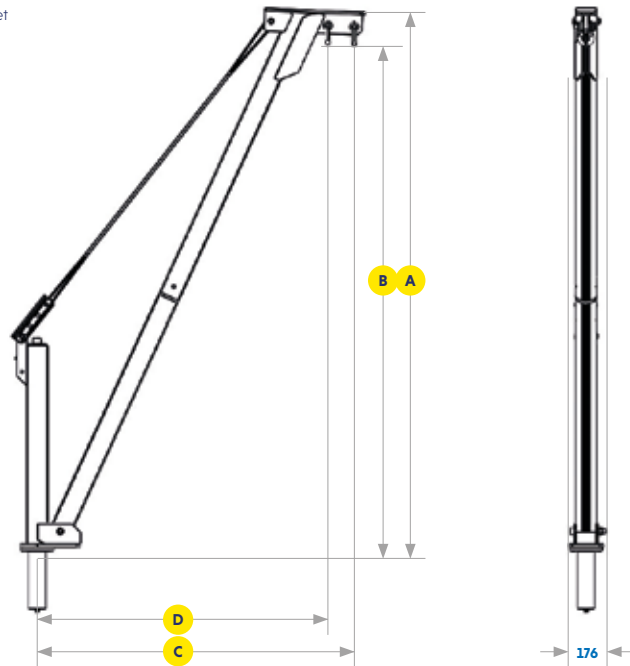

WLL	Radius Adjustment Points	Dimensions [mm]			
		A	B	C*	D*
500kg	1	2036	1925	1200	1100
	2	2139	2028	1000	900
	3	2218	2107	800	700

\*Radii achieved at = 75% WLL

# PORTADAVIT® 1000

- A** Overall height from top of socket
- B** Height to shackles
- C** Radius to outer shackle
- D** Radius to inner shackle

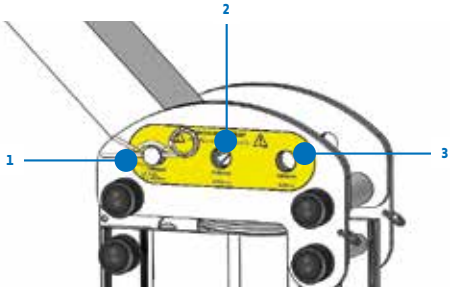
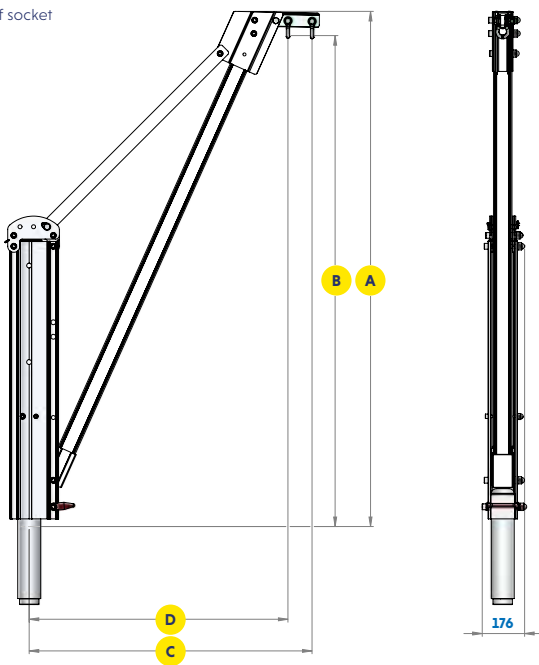

WLL	Radius Adjustment Points	Dimensions [mm]			
		A	B	C*	D*
1000kg	1	2100	2000	1200	1100
	2	2150	2050	1100	1000
	3	2200	2100	1000	900

\*Radii achieved at ≈ 75% WLL

# PORTADAVIT QUANTUM®

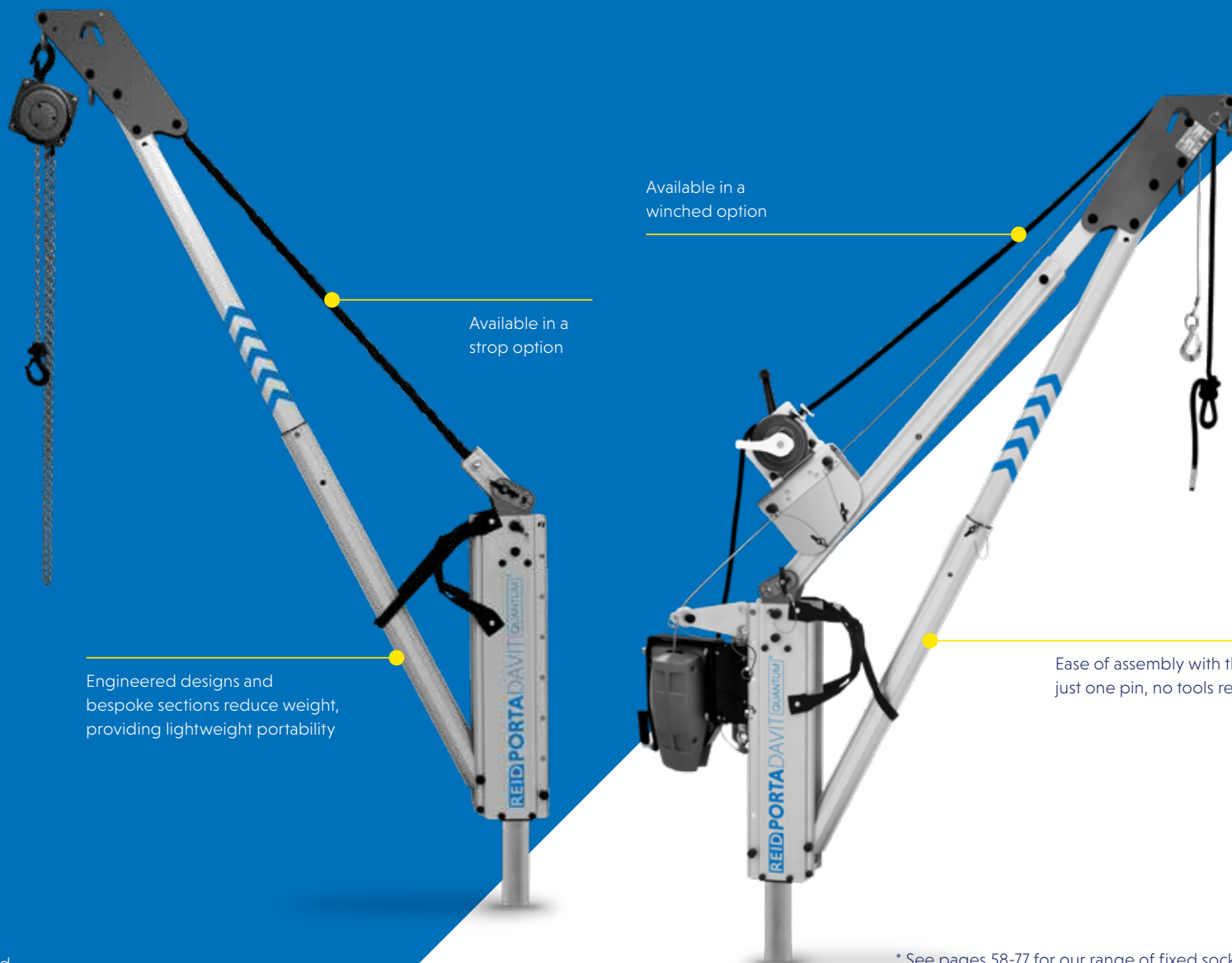

Available in a winched option

Available in a strop option

Engineered designs and bespoke sections reduce weight, providing lightweight portability

Ease of assembly with the use of just one pin, no tools required

This product is patented

\* See pages 58-77 for our range of fixed sockets and portable bases.

Our **PORTADAVIT<sup>QUANTUM</sup>** is a rapidly deployable, lightweight solution to heavy lifting and lowering of goods and personnel. Weighing from just 18.5kg when fully assembled, it can be manually operated by one person while maintaining a lifting capacity of up to 600kg.

## Key features

- › EN795:2012 Certified
- › ATEX Certified
- › Can support goods and personnel lifting;
  - › Goods WLL of up to 600kg
  - › Personnel WLL of up to 300kg
- › Ease of assembly with the use of just one pin, no tools required
- › Can be rotated 360° under a full load
- › Designed with a universal kingpin which is compatible for all REID sockets
- › Easy radius adjustment
- › Engineered designs and bespoke sections reduce weight, providing lightweight portability

## Configurations

The **PORTADAVIT<sup>QUANTUM</sup>** is available in a strop and winched version for use with a range of lifting equipment.



## Features & Performance

	PDQ 1	PDQ 2
<b>Accreditations, Certifications &amp; Standards</b>		
EN795:2012	✓	✓
AS/NZS 5532:2013	✓	✓
ATEX Certified [Zone 2]	✓	✓
ATEX Certified [Zone 1]	Optional	Optional
<b>Capacity</b>		
Maximum Goods Lifting [kg]	600	500
Maximum Personnel Lifting [kg]	300	250
Fall Arrest [Persons]	1	1
<b>Dimensions</b>		
Maximum Reach [mm]	1200	1500
Maximum Height of Lift [mm]	2111	1957
<b>Socket Diameter</b>		
65mm	✓	✓
<b>Socket Options</b>		
Top Mount	✓	✓
Flush Mount	✓	✓
Side Mount	✓	✓
Bridge Mount	✓	✓
Pedestal	✓	✓
Extension Post	✓	✓
<b>Standard Features</b>		
One Piece Unit	✓	✓
Multiple Accessory Attachment	✓	✓
Shackle Lifting Points	✓	✓
Weight < 25kg	✓	✓
<b>Optional Extras</b>		
Winch Capable	✓	✓
Rotational Handle	✓	✓
<b>Finishes</b>		
Anodised	✓	✓
316SS Fixings	Optional	Optional
Marine Spec	Optional	Optional

Dimensions in the table are approximate values. For more accurate details please refer to the Dimension Table.  
 All line items marked with a '✓' come as standard. All line items marked with a 'X' are not available.  
 All line items marked with 'optional' are available as an option and may incur additional costs.

**PORTADAVIT** QUANTUM®

- A** Overall height
- B** Height to outer shackle
- C** Height to inner shackle
- D** Radius to outer shackle
- E** Radius to inner shackle

WINCHED [Type W]

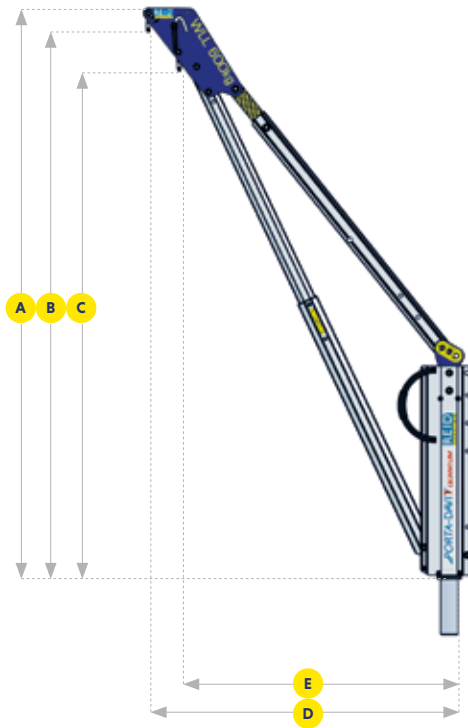

STROP [Type S]

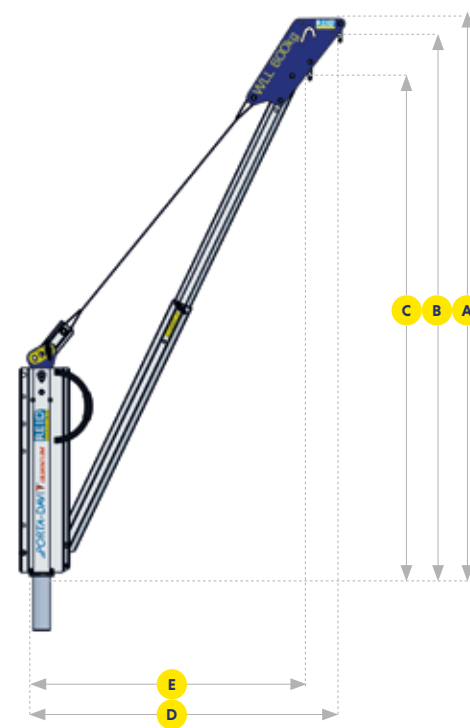

Product Code	System Weight [kg]	WLL	Radius Adjustment Points	Dimensions [mm]				
				A	B	C	D*	E*
PDQ1S	18.5	600kg	1	2007	1935	1799	1200	1100
PDQ1W	22.5		2	2061	1989	1848	1100	1000
			3	2111	2039	1892	1000	900
PDQ2S	19	500kg	1	1837	1766	1647	1500	1400
PDQ2W	23		2	1899	1827	1703	1400	1300
			3	1957	1885	1755	1300	1200

\*Radii achieved at = 75% WLL

# > Davit Accessories



## > Winch Brackets

We offer a wide range of winch brackets for common goods and personnel winches. The winch brackets can be attached to each Davit to support the application required. Operations & Assembly instructions can be found for each device on our website.



## > SRL Brackets

We offer a range of universal bracket solutions that allow for use of Safety Retrieval Lifeline devices with our Davit range. Operations & Assembly instructions can be found for each device on our website.



## > Rotational Handle

Our rotational handle can be fitted to the column of the davit to aid in the rotation under load. The rotational handle can be fitted to our TDAVIT and PORTADAVIT <sup>QUANTUM</sup> systems.

Product Code	Description
RATD000006	Rotation Handle to suit T-Davit and PDQ

## > Supported Winch & SRL Devices

We support a wide range of devices with our custom brackets to fit our product solutions. For a complete list of all supported devices and solutions, please see page 57.





## Winch & SRL Brackets Part Codes

	TDAVIT*	PORTADAVIT <sup>[QUANTUM]</sup> Column	PORTADAVIT <sup>[QUANTUM]</sup> Single Winched Backstay	PORTADAVIT <sup>[QUANTUM]</sup> Double Winched Backstay	PORTADAVIT*	
<b>Personnel Winches</b>	<b>G.Winch</b>	RAWB005200	RAWB005200	RAWB005206	N/A	RAWB005203
	<b>Guardian Checkmate</b>	RAWB001200	RAWB001200	RAWB001206	N/A	RAWB001203
	<b>IKAR PLW</b>	RAWB004200	RAWB004200	RAWB004206	N/A	RAWB004203
	<b>MSA Rescuer</b>	RAWB008000	RAWB008000	RAWB008006	N/A	RAWB008003
	<b>MSA Workman</b>	RAWB008000	RAWB008000	RAWB008006	N/A	RAWB008003
	<b>3M SALA Winch</b>	RAWB003000	RAWB003000	RAWB003003	N/A	RAWB003000
	<b>3M DBI SALA Digital Winch</b>	RAWB003000	RAWB003000	RAWB003003	N/A	RAWB003000
	<b>Tuffbuilt Pro Series 1</b>	RAWB009200	RAWB009200	RAWB009206	N/A	RAWB009203
	<b>Tuffbuilt Pro Series 2</b>	RAWB009300	RAWB009300	RAWB009306	N/A	RAWB009303
<b>SRL Devices</b>	<b>Guardian FABXR</b>	RAWB001000	RAWB001000	RAWB001000	RAWB001010	RAWB001000
	<b>Tractel Blocfor</b>	RAWB002000	RAWB002000	RAWB002000	RAWB002010	RAWB002000
	<b>3M Rebel Protect A</b>	RAWB003000	RAWB003000	RAWB003006	RAWB003010	RAWB003003
	<b>SALA Sealed Block</b>	RAWB003000	RAWB003000	RAWB003006	RAWB003010	RAWB003003
	<b>3M Sala Ultra-Lok</b>	RAWB003000	RAWB003000	RAWB003006	RAWB003010	RAWB003003
	<b>IKAR HRA</b>	RAWB004000	RAWB004000	RAWB004000	RAWB004010	RAWB004000
	<b>Globestock G-Saver GSE 414G</b>	RAWB005500	RAWB005500	RAWB005500	RAWB005510	RAWB005500
	<b>Globestock G-Saver GSE 420G</b>	RAWB005000	RAWB005000	RAWB005000	RAWB005010	RAWB005000
	<b>Globestock G-Saver GSE 434G</b>	RAWB005000	RAWB005000	RAWB005000	RAWB005010	RAWB005000
<b>Ridgegear</b>	RAWB006000	RAWB006000	RAWB006000	RAWB006010	RAWB006000	



## Bases & Sockets

We offer a wide range of portable bases, sockets and extensions which offer full versatility and compatibility with our Davit range, all of which are designed to make light work of lifting and lowering.

**60**   **PORTABASE**

**74**   **Sockets & Extensions**



# PORTABASE<sup>®</sup> H Base

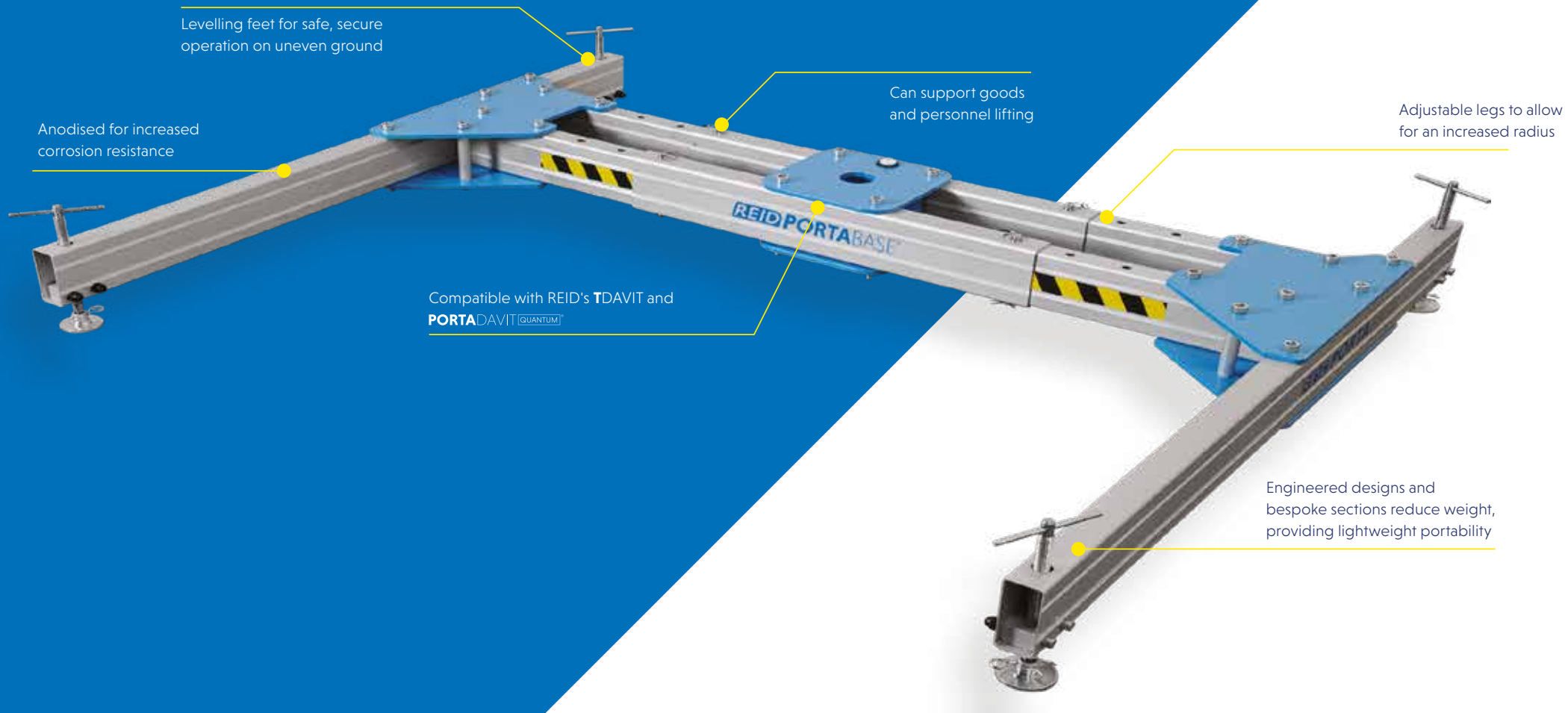

Levelling feet for safe, secure operation on uneven ground

Anodised for increased corrosion resistance

Can support goods and personnel lifting

Adjustable legs to allow for an increased radius

Compatible with REID's TDAVIT and PORTADAVIT<sup>QUANTUM</sup>

Engineered designs and bespoke sections reduce weight, providing lightweight portability

The **PORTABASE H Base** is a three piece, portable system which can be easily broken down for transportation.

Expertly engineered to provide full use and compatibility with the **TDAVIT** and **PORTADAVIT<sup>QUANTUM</sup>** providing maximum flexibility where the installation or use of a fixed socket is not possible.

The **PORTABASE H Base** enables our Davit products to be used for lifting goods up to 600kg, as well as providing access and egress for confined space and work at height tasks, including as an anchor point for fall arrest scenarios.

## Key features

- EN795:2012 Certified
- Can support goods and personnel lifting;
  - Goods WLL of up to 600kg
  - Personnel WLL of up to 300kg
- Breaks down in to 3 components for ease of transportation
- Designed for ease of assembly using pins, with no bolted sections or the need for tools
- Detachable legs for ease of transportation
- Levelling feet designed to support the system to function correctly on uneven ground
- Compatible with the use of **TDAVIT** and **PORTADAVIT<sup>QUANTUM</sup>**
- Clean, anodised finish for increased corrosion resistance
- Engineered designs and bespoke sections reduce weight, providing lightweight portability



**600KG  
WLL**



**1-2 PERSON  
ASSEMBLY**



**3 MANAGEABLE  
COMPONENTS**



**EN795  
CERTIFIED**

## Features & Performance

H BASE	
<b>Accreditations, Certifications &amp; Standards</b>	
EN795:2012	✓
ANSI Z359.18-17	✓
ATEX Certified [Zone 2]	Optional
IRATA	✓
<b>Capacity</b>	
Maximum Goods Lifting [kg]	600
Maximum Personnel Lifting [kg]	300
Fall Arrest [Persons]	1
Maximum Radius [mm]	800
<b>Dimensions</b>	
Minimum Base Width [mm]	1430
Maximum Base Width [mm]	1830
Minimum Base Height [mm]	217
Maximum Base Height [mm]	332
Overall Length [mm]	1600
<b>Compatible Products</b>	
Porta Davit Quantum [Restricted]	✓
Porta Davit Quantum [1]	X
Porta Davit Quantum [2]	X
T Davit [Shackled]	✓
T Davit [Winched]	✓
T Davit [Double Winched]	✓
<b>Standard Features</b>	
Levelling Feet	✓
Individual Component Weight < 25kg	✓
No Tools Required	✓
<b>Finishes</b>	
Anodised / Powder Coated	✓
316SS Fixings	Optional
Marine Spec	Optional

Dimensions in the table are approximate values. For more accurate details please refer to the Dimension Table.

All line items marked with a '✓' come as standard. All line items marked with a 'X' are not available.

All line items marked with 'optional' are available as an option and may incur additional costs.

# PORTABASE<sup>®</sup> Counterbalance

Levelling feet for safe, secure operation on uneven ground

Detachable folding basket with integrated swivel-locking castors

Anodised for increased corrosion resistance

Adjustable legs to allow for an increased radius

Compatible with REID's TDAVIT and PORTADAVIT<sup>QUANTUM</sup>

Engineered designs and bespoke sections reduce weight, providing lightweight portability

Swivel castors for increased portability

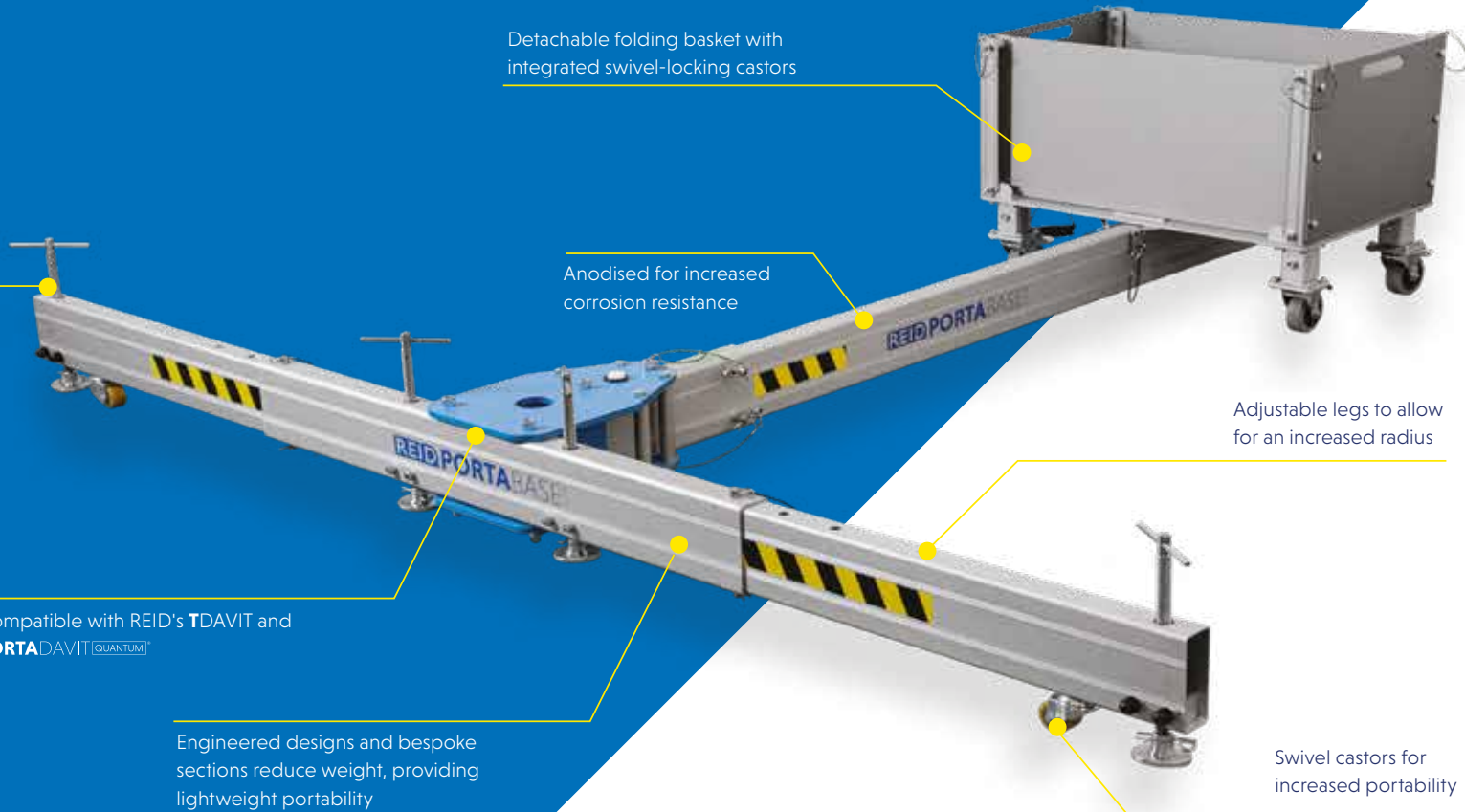

The **PORTABASE** Counterbalance is a five piece, portable system which can be easily broken down for transportation.

Expertly engineered, the system is compatible with the **TDAVIT** and **PORTADAVIT<sup>QUANTUM</sup>** providing maximum flexibility where the installation or use of a fixed socket is not possible. The product is quick and easy to set up with no tools required.

The **PORTABASE** Counterbalance enables our Davit products to be used for lifting goods up to 600kg, as well as providing access and egress for confined space and work at height tasks, including as an anchor point for fall arrest scenarios.

## Key features

- EN795:2012 Certified
- Can support goods and personnel lifting;
  - Goods WLL of up to 600kg
  - Personnel WLL of up to 300kg
- Breaks down in to 5 components for ease of transportation and stowage
- Designed for ease of assembly using pins, with no bolted sections or the need for tools
- Detachable legs and foldable basket for ease of transportation
- Levelling feet designed to support the system to function correctly on uneven ground
- Integrated swivel castors, as standard
- Compatible with the use of **TDAVIT** and **PORTADAVIT<sup>QUANTUM</sup>**
- Clean, anodised finish for increased corrosion resistance
- Uses 20kg hand weights for the basket, reducing manual handling risks
- Engineered designs and bespoke sections reduce weight, providing lightweight portability

## Configurations

Height adjustable feet can be fitted to the **PORTABASE** Counterbalance basket, providing an adjustment of 230mm. For more information contact REID.



**600KG  
WLL**



**1-2 PERSON  
ASSEMBLY**



**5 MANAGEABLE  
COMPONENTS**



**EN795  
CERTIFIED**

## Features & Performance

### COUNTERBALANCE

#### Accreditations, Certifications & Standards

EN795:2012	✓
ANSI Z359.18-17	✓
ATEX Certified [Zone 2]	Optional
IRATA	✓

#### Capacity

Maximum Goods Lifting [kg]	600
Maximum Personnel Lifting [kg]	300
Fall Arrest [Persons]	1
Maximum Radius [mm]	1200

#### Dimensions

Minimum Base Width [mm]	2320
Maximum Base Width [mm]	2720
Minimum Base Height [mm]	240
Maximum Base Height [mm]	332
Overall Length [mm]	2415

#### Compatible Products

Porta Davit Quantum [Restricted]	✓
Porta Davit Quantum [1]	✓
Porta Davit Quantum [2]	X
T Davit [Shackled]	✓
T Davit [Winched]	✓
T Davit [Double Winched]	✓

#### Standard Features

Levelling Feet	✓
Individual Component Weight < 25kg	✓
No Tools Required	✓
Swivel Castors	✓

#### Finishes

Anodised / Powder Coated	✓
316SS Fixings	Optional
Marine Spec	Optional

Dimensions in the table are approximate values. For more accurate details please refer to the Dimension Table.

All line items marked with a '✓' come as standard. All line items marked with a 'X' are not available.

All line items marked with 'optional' are available as an option and may incur additional costs.

# ▶ PORTABASE<sup>®</sup> Counterbalance Trailer Hitch

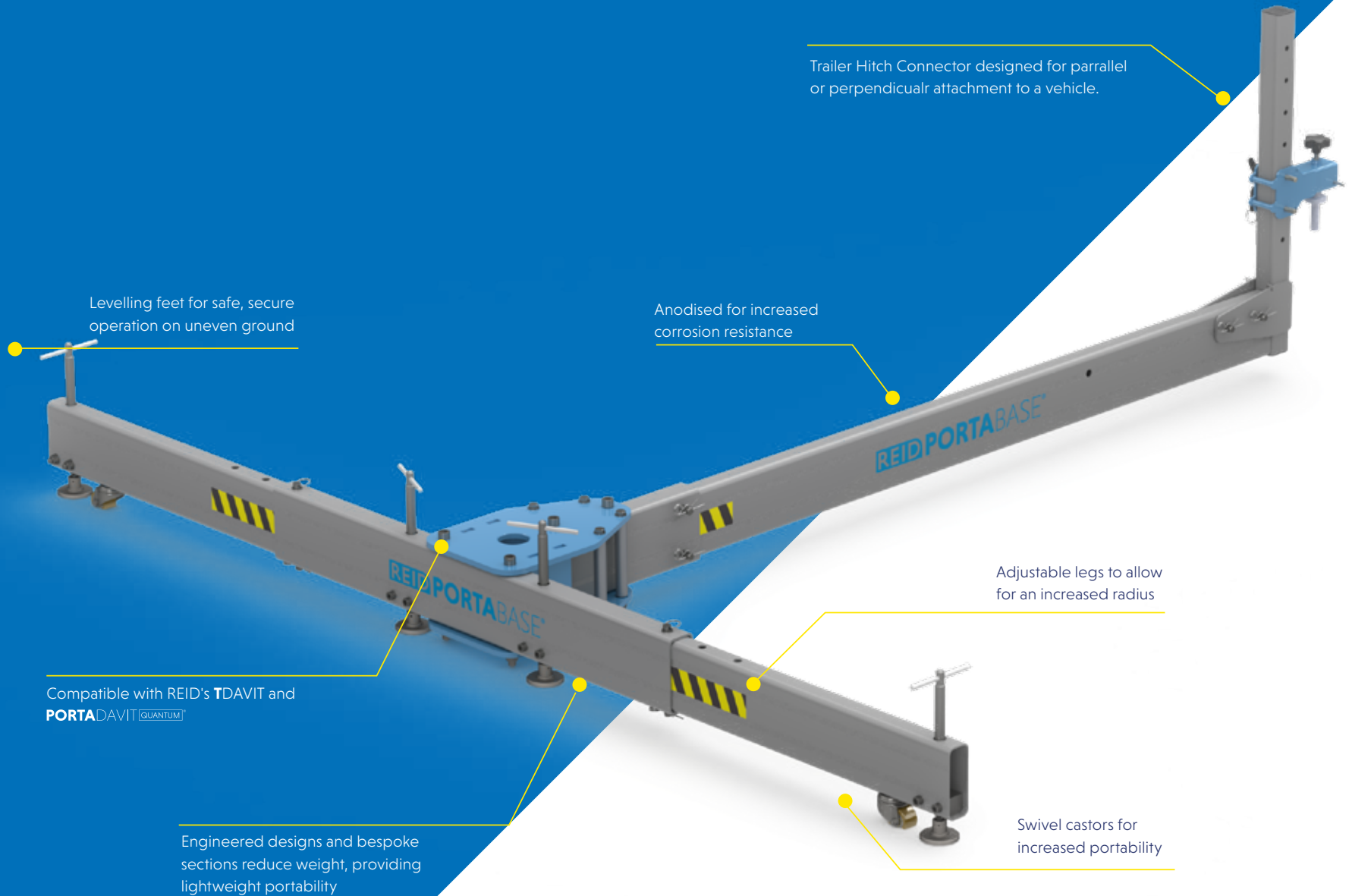

Trailer Hitch Connector designed for parallel or perpendicular attachment to a vehicle.

Levelling feet for safe, secure operation on uneven ground

Anodised for increased corrosion resistance

Adjustable legs to allow for an increased radius

Compatible with REID's TDAVIT and PORTADAVIT<sup>QUANTUM</sup>

Engineered designs and bespoke sections reduce weight, providing lightweight portability

Swivel castors for increased portability



The **PORTABASE** Counterbalance Trailer Hitch is a portable system which can be easily broken down for transportation. The product is quick and easy to set up with no tools required.

The system is compatible with the **TDAVIT** and **PORTA****DAVIT** <sup>QUANTUM</sup> providing maximum flexibility where the installation or use of a fixed socket is not possible. This system has been designed to attach to a vehicle with a tow bar such as a Van or Truck. When in use with our Davits, it can be used for lifting goods up to 450kg as well as providing access and egress for confined space tasks.

## Key features

- EN795:2012 Certified
- Can support goods and personnel lifting;
  - Goods WLL of up to 450kg
  - Personnel WLL of up to 225kg
- Breaks down in to 6 components for ease of transportation and stowage
- Incredibly lightweight structure with full system weighing 45kg
- Designed for ease of assembly using pins, with no bolted sections or the need for tools
- Levelling feet designed to support the system to function correctly on uneven ground
- Integrated swivel castors, as standard
- Compatible with the use of **TDAVIT** and **PORTA****DAVIT** <sup>QUANTUM</sup>
- Easy connection to a van or truck weighing 2000kg
- Can be connected parallel or perpendicular to the vehicle
- Clean, anodised finish for increased corrosion resistance
- Engineered designs and bespoke sections reduce weight, providing lightweight portability

## Configurations

If you have already own a **PORTABASE** Counterbalance, the Trailer Hitch Connector can be bought separately [please contact REID for further information].



**450KG  
WLL**



**1 PERSON  
ASSEMBLY**



**6 COMPONENTS  
AT 45KG**



**EN795  
CERTIFIED**

## Features & Performance

### COUNTERBALANCE TRAILER HITCH

#### Accreditations, Certifications & Standards

EN795:2012	✓
ANSI Z359.18-17	✓
ATEX Certified [Zone 2]	Optional
IRATA	✓

#### Capacity

Maximum Goods Lifting [kg]	450
Maximum Personnel Lifting [kg]	225
Fall Arrest [Persons]	1
Maximum Radius [mm]	1200

#### Dimensions

Minimum Base Width [mm]	2320
Maximum Base Width [mm]	2720
Minimum Base Height [mm]	240
Maximum Base Height [mm]	332
Overall Length [mm]	2620

#### Compatible Products

Porta Davit Quantum [Restricted]	✓
Porta Davit Quantum [1]	✓
Porta Davit Quantum [2]	X
T Davit [Shackled]	✓
T Davit [Winched]	✓
T Davit [Double Winched]	✓

#### Features

Levelling Feet	✓
Individual Component Weight < 25kg	✓
No Tools Required	✓
Swivel Castors	✓

#### Finishes

Anodised / Powder Coated	✓
316SS Fixings	Optional
Marine Spec	Optional

Dimensions in the table are approximate values. For more accurate details please refer to the Dimension Table.

All line items marked with a '✓' come as standard. All line items marked with a 'X' are not available.

All line items marked with 'optional' are available as an option and may incur additional costs.

**PORTABASE® H Base**

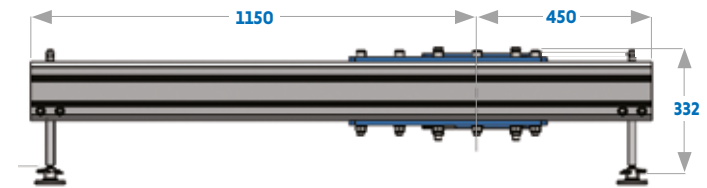
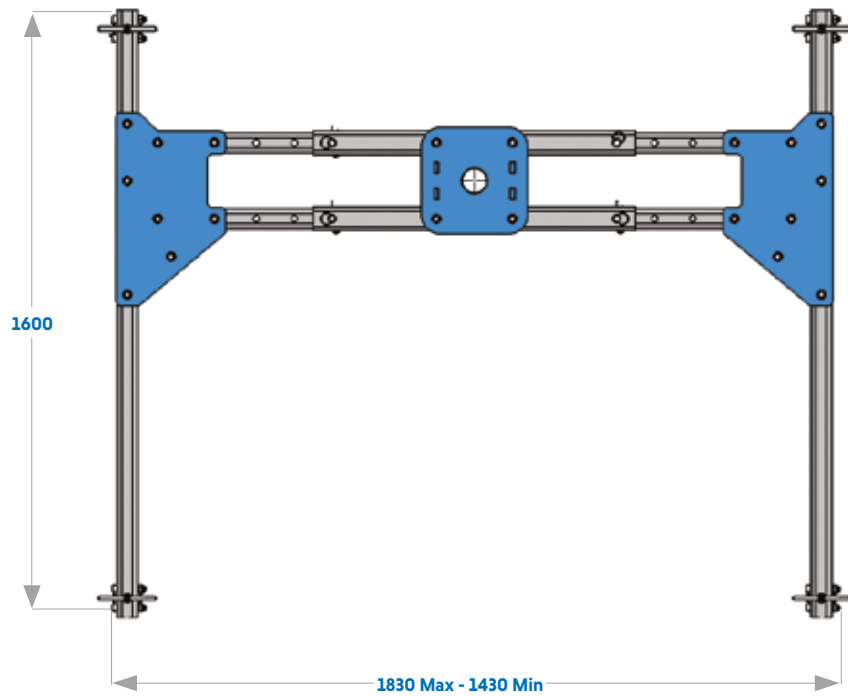

Product Code	Description
PBHB00001	PORTABASE H Base Standard - Max 800mm Radius

**Dimensions**

Component	Weight [kg]
Central Hub	18.5kg
Leg Assembly [Each]	22.5kg
<b>Total Weight</b>	<b>63.5kg</b>

# PORTABASE® Counterbalance

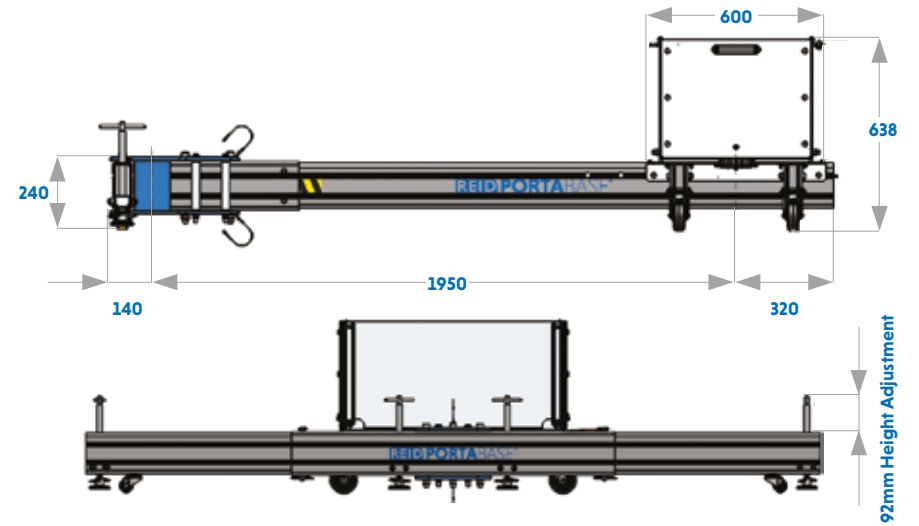
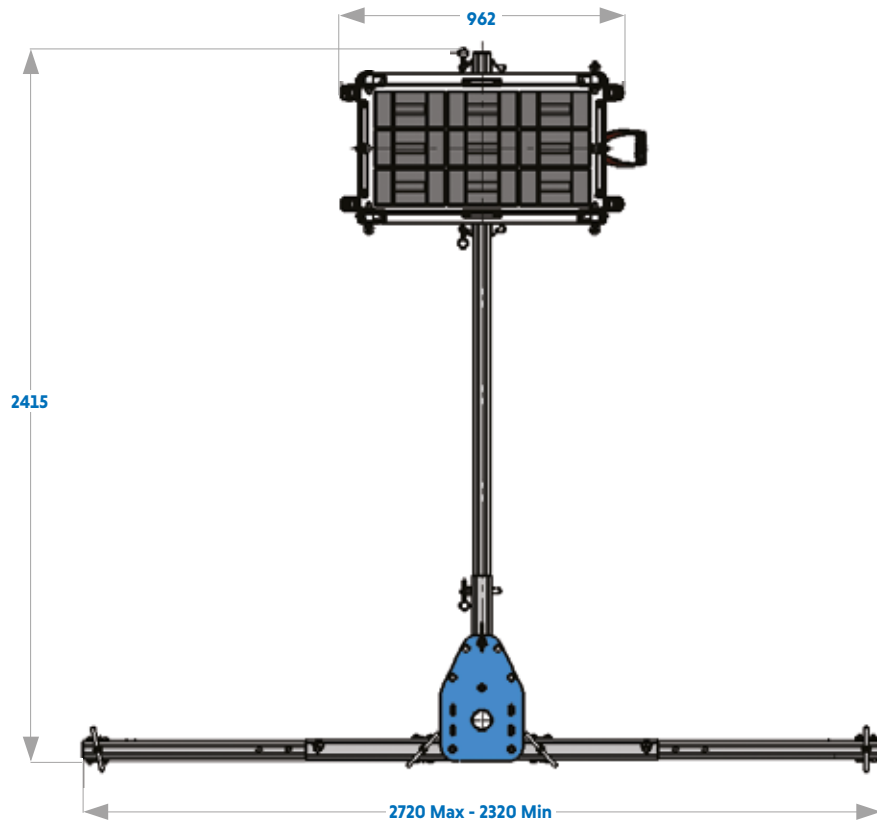

Dimensions

Component	Weight [kg]
Central Hub	24kg
Leg Assembly [Each]	5kg
Tail	6kg
Basket [Empty]	38kg
<b>Total Weight</b>	<b>78kg</b>

Product Code	Description
<b>PBCB00001</b>	PORTABASE Counterbalance Standard - Max 1200mm Radius
<b>RAHW00001</b>	Hand Weight [1 x 20kg]
<b>RAHW00003</b>	360kg Hand Weight Set [18 x 20kg]
<b>RAHW00004</b>	540kg Hand Weight Set [27 x 20kg]
<b>RAPBCB0001</b>	Porta Base Counterbalance Basket Height Adjustment Kit



A height adjustment kit can be fitted to the basket, providing an adjustment of 230mm.

**PORTABASE®** Counterbalance Trailer Hitch

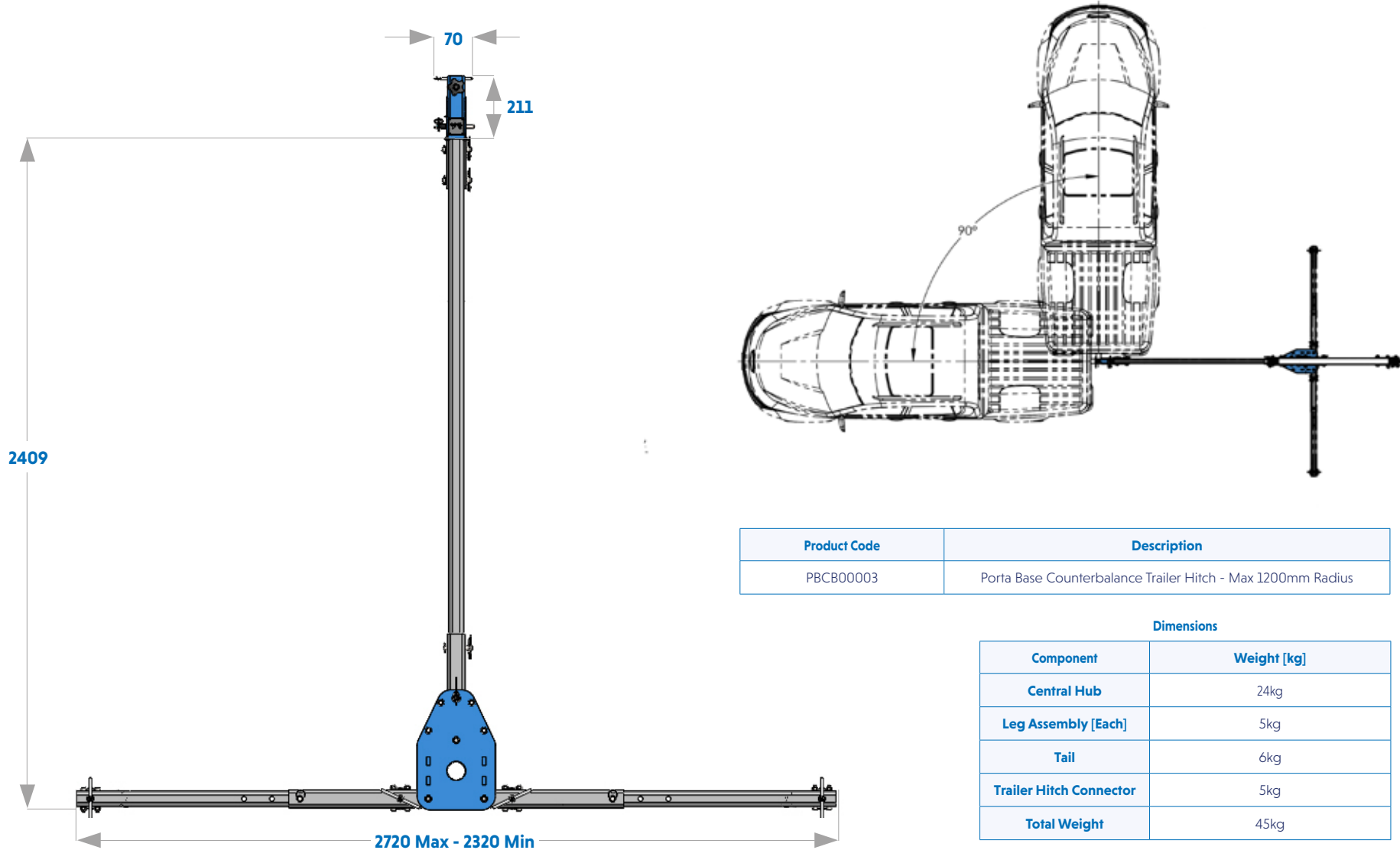

Product Code	Description
PBCB00003	Porta Base Counterbalance Trailer Hitch - Max 1200mm Radius

Dimensions	
Component	Weight [kg]
Central Hub	24kg
Leg Assembly [Each]	5kg
Tail	6kg
Trailer Hitch Connector	5kg
<b>Total Weight</b>	<b>45kg</b>

## PORTABASE® Counterbalance Trailer Hitch Connector

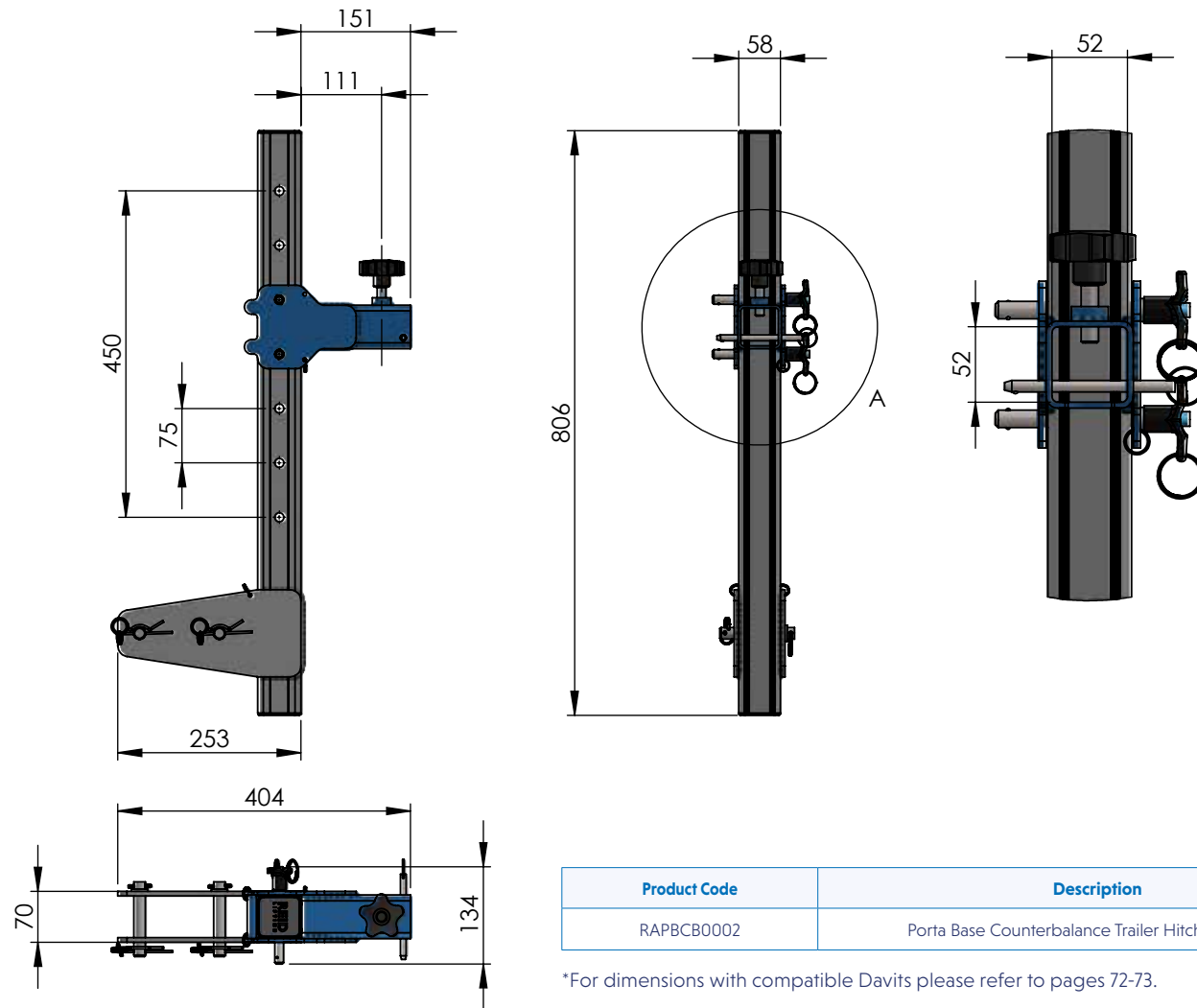

Product Code	Description
RAPBCB0002	Porta Base Counterbalance Trailer Hitch Connector

\*For dimensions with compatible Davits please refer to pages 72-73.

**PORTABASE® H Base | TDAVIT® Double Winched**

**Position A**

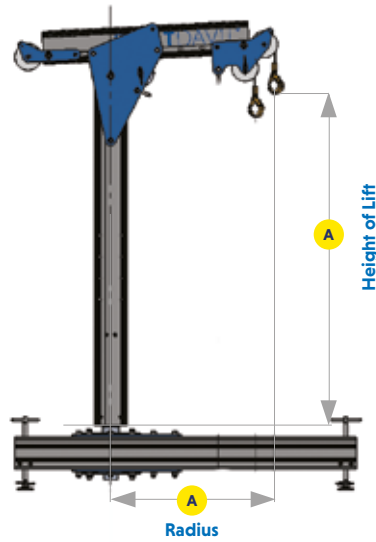

**Position B**

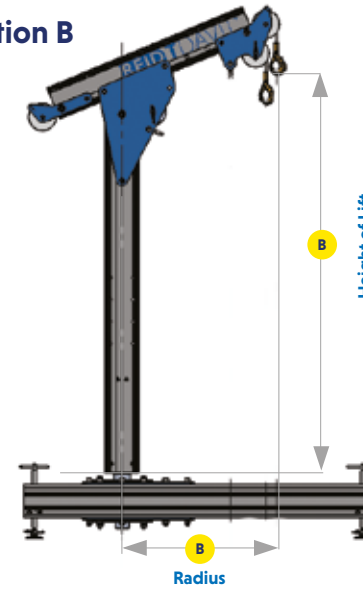

PRODUCT CODE	HEIGHT OF LIFT (HOL) (MM)		RADIUS (MM)		WLL			WEIGHT (KG)
	Position A	Position B	Position A	Position B	Goods [kg]	Personnel [kg]	Fall Arrest	
<b>TDDWA3A0</b>	1290	1540	800	740	600	300	1 person	34
<b>TDDWA4A0</b>	1605	1855	800	740	600	300	1 person	36
<b>TDDWA5A0</b>	1915	2165	800	740	600	300	1 person	39

# PORTABASE® H Base | PORTADAVIT QUANTUM®

- A** Overall height
- B** Height to outer shackle
- C** Height to inner shackle
- D** Radius to outer shackle
- E** Radius to inner shackle

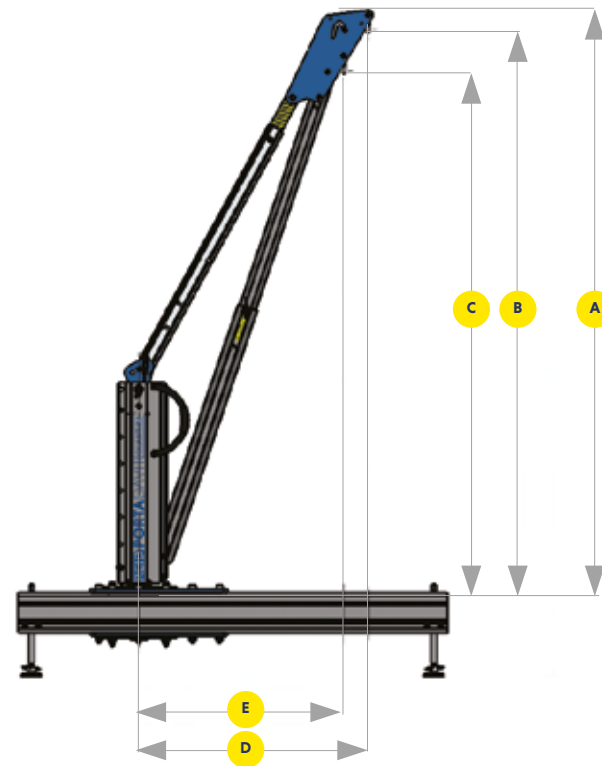

DIMENSIONS (MM)

PRODUCT CODE	GOODS WLL (KG)	PERSONNEL WLL (KG)	FALL ARREST	RADIUS ADJUSTMENT POINTS	A	B	C	D*	E*
PDQR	600	300	1 person	1	2150	2078	1928	800	700

\*Radii achieved at ≈ 75% WLL

**PORTABASE® Counterbalance | TDAVIT® Double Winched**

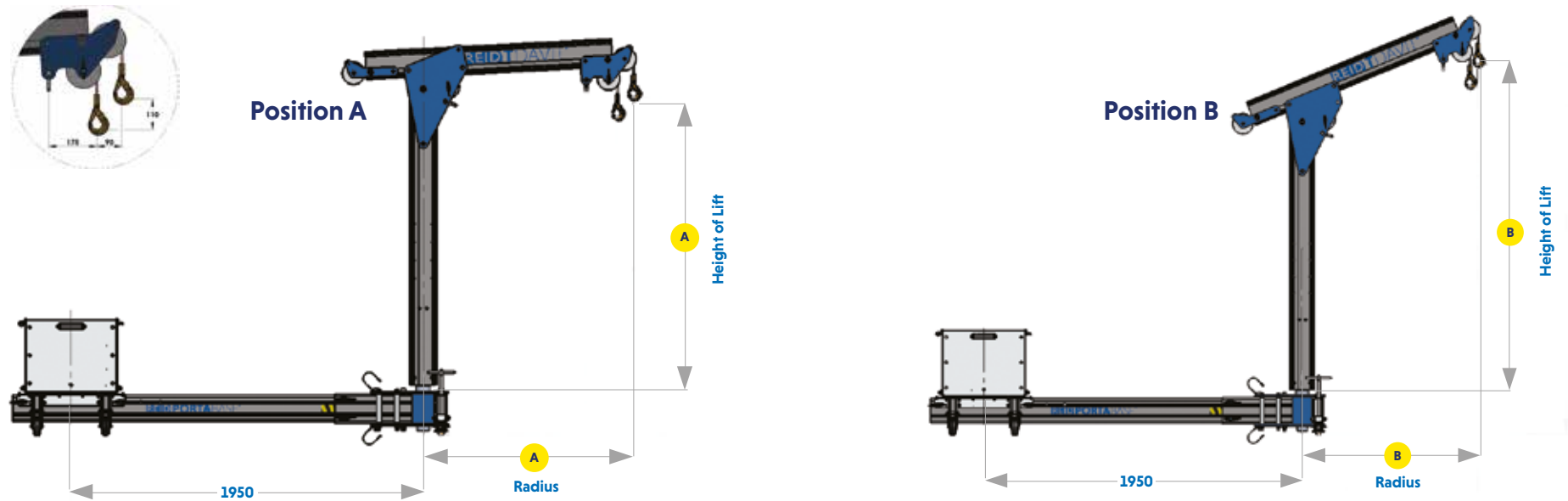

PRODUCT CODE	HEIGHT OF LIFT (HOL) (MM)		RADIUS (MM)		WLL			WEIGHT (KG)
	Position A	Position B	Position A	Position B	Goods [kg]	Personnel [kg]	Fall Arrest	
<b>TDDWA3A0</b>	1290	1540	800	740	600	300	1 person	34
<b>TDDWA3A1</b>	1300	1615	1000	925	500	250	1 person	35
<b>TDDWA3A2</b>	1310	1690	1200	1110	400	200	1 person	36
<b>TDDWA4A0</b>	1605	1855	800	740	600	300	1 person	36
<b>TDDWA4A1</b>	1615	1930	1000	925	500	250	1 person	37
<b>TDDWA4A2</b>	1625	2005	1200	1110	400	200	1 person	38
<b>TDDWA5A0</b>	1915	2165	800	740	600	300	1 person	39
<b>TDDWA5A1</b>	1925	2240	1000	925	500	250	1 person	40
<b>TDDWA5A2</b>	1935	2315	1200	1110	400	200	1 person	41



# PORTABASE® Counterbalance | PORTADAVIT<sup>QUANTUM</sup>

- A** Overall height
- B** Height to outer shackle
- C** Height to inner shackle
- D** Radius to outer shackle
- E** Radius to inner shackle

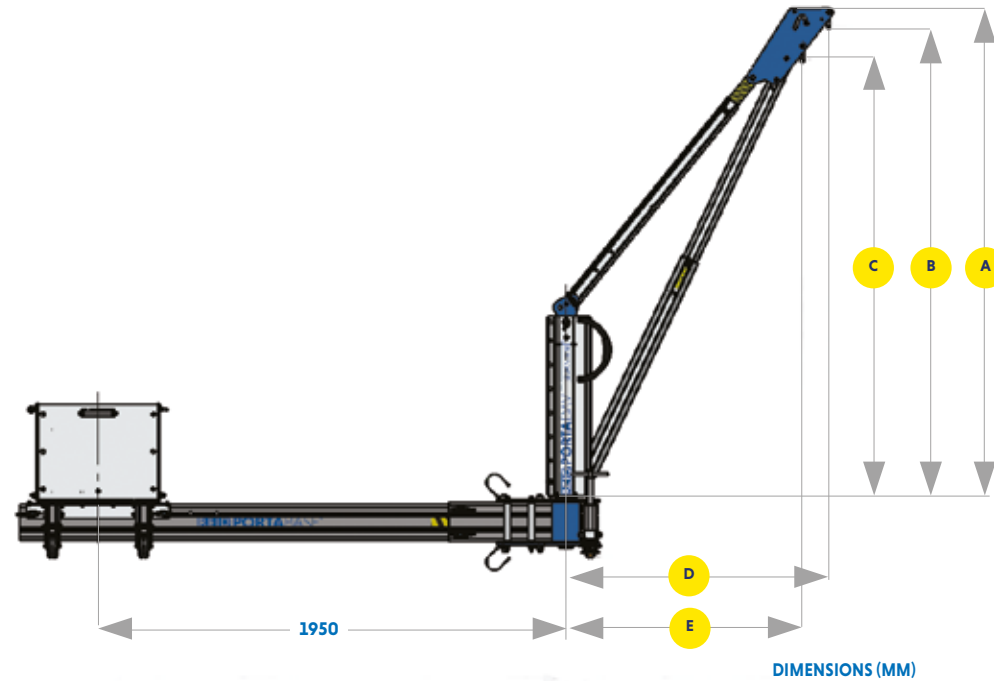

PRODUCT CODE	GOODS WLL (KG)	PERSONNEL WLL (KG)	FALL ARREST	RADIUS ADJUSTMENT POINTS	DIMENSIONS (MM)				
					A	B	C	D*	E*
PDQRW	600	300	1 person	1	2150	2078	1928	800	700
PDQ1W PDQ1S	400	200	1 person	1	2007	1935	1799	1200	1100
	450	225		2	2061	1989	1848	1100	1000
	500	250		3	2111	2039	1892	1000	900

\*Radii achieved at ≈ 75% WLL

# > SOCKETS & EXTENSIONS

We manufacture a range of standard sockets, socket extensions and pedestals that are fully compatible with our davit range which can be used for goods lifting, personnel lifting and in many cases fall protection applications. They are also suitable for a variety of structures [subject to engineer approval]. Available in aluminium, galvanised steel and stainless steel. We can also manufacture customised sockets and pedestals on request. Our socket extensions are designed to provide additional height of reach over obstacles, protective rails or walls.



## > Sockets

Our sockets are fully compatible with our davit range and are suitable for a variety of structures. Available in aluminium, galvanised steel and stainless steel.

We offer sockets with two kingpin diameter sizes [65mm and 95mm] to fit our range of davits.

**Our socket options includes:**

- > **Top Mount**
- > **Side Mount**
- > **Bridge Mount**
- > **Flush Mount**

We can also offer customised sockets, which are bespoke made and developed for non-typical installations. To discuss your requirements with us, contact us on [enquiries@reidlifting.com](mailto:enquiries@reidlifting.com).

Sockets



**Flush Mount**



**Bridge Mount**



**Side Mount**



**Top Mount**

Height of Lift:  
+264mm

Our sockets are part of a fall protection and personnel lifting system, which includes a REID Lifting Davit. Only sockets manufactured by REID Lifting may be used with our Davit's. Failure to use REID sockets will invalidate any product certification and warranty and exposes the user to unnecessary and unwarranted risk. Before fixing always consult a structural engineer to confirm suitability for the loads that will be imposed during use, allowing for the required safety factors.

## > Pedestals

Our pedestal sockets are similar to top mount sockets and are manufactured from lightweight aluminium. Our pedestals are designed to provide additional lift height or reach over obstacles, protective rails or walls.

We offer pedestals which are suitable for use with our 65mm kingpin davit range.

**Our pedestals are available in three standard sizes:**

- > 500mm
- > 800mm
- > 1100mm

They can also be customised to meet our customers' specific requirements. To discuss your requirements with us, contact us on [enquiries@reidlifting.com](mailto:enquiries@reidlifting.com).

## > Socket Extensions

Our socket extensions are designed to provide additional lift height or reach over obstacles, protective rails or walls for 65mm socket/kingpin davits. Made from lightweight aluminium alloy, with handles for lifting and carrying, they're designed to be easy to use. Simply insert them into the existing socket and assemble a standard davit, as normal, using the extension as its socket.

**Our socket extensions are available in three standard sizes:**

- > 500mm
- > 800mm
- > 1100mm

They can also be customised to meet our customers' specific requirements.

\*When fixing sockets to structures, customers must always seek the guidance of a suitably qualified engineer to ensure that the structure is able to support the required loads.

\*\* Socket extensions are only suitable to be used with our socket range and cannot be used with a pedestal. For further information please contact your REID representative.



**Disclaimer:** All REID sockets & extensions have been designed, developed and tested for safe use with REID's equipment and form a key part of the integrity of the total system. Should non-standard third party sockets be used, REID Lifting's Declaration of Conformity & Incorporation on the products is negated. i.e. The system becomes the responsibility of the client.

## › Top Mount Socket



- › Suitable for use with our full davit range
- › EN795:2012 certified and meets requirements of IRATA ICOP
- › Galvanised Steel Top Mount[STMG0500V2] meets requirements of BS8610:2017
- › Secured using 4nr. M16 anchors [not supplied]
- › Suitable for bolting into existing concrete, steel structures or through fixing in other substrates
- › Comes complete with cover

Product Code	Description	Material	Weight [kg]	Diameter [mm]
STMG0500V2	Socket Top Mount 65 GMS	Galvanised Steel	13	65
STMS0500V2	Socket Top Mount 65 316SS	Stainless Steel	17	65
STMA0500	Socket Top Mount 65 Aluminium Anodised	Aluminium	9	65
STMG1000	Socket Top Mount 95 GMS	Galvanised Steel	29	95
STMS1000	Socket Top Mount 95 316SS	Stainless Steel	30	95

## › Bridge Mount Socket

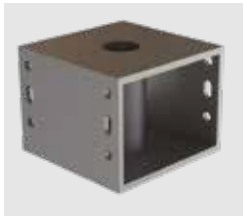

- › Suitable for use with 65mm REID davits
- › EN795:2012 certified and meets requirements of IRATA ICOP
- › Secured using 4nr. M16 anchors [not supplied]
- › Suitable for bolting into steel structures
- › Designed to fit open mesh grating or flush with structural steel work

Product Code	Description	Material	Weight [kg]	Diameter [mm]
SBMG0500	Socket Bridge Mount 65 GMS	Galvanised Steel	19	65
SBMS0500	Socket Bridge Mount 65 316SS	Stainless Steel	19	65
SBMA0500	Socket Bridge Mount 65 Aluminium Anodised	Aluminium	7	65

## › Side Mount Socket



- › Suitable for use with our full davit range
- › EN795:2012 certified and meets requirements of IRATA ICOP
- › Galvanised Steel Side Mount[SSMG0500V2] meets requirements of BS8610:2017
- › Secured using 4nr. M16 anchors [not supplied]
- › Suitable for mounting on the side of concrete or steel structures
- › A brace plate can be supplied for thin-walled concrete

Product Code	Description	Material	Weight [kg]	Diameter [mm]
SSMG0500V2	Socket Side Mount 65 GMS	Galvanised Steel	13	65
SSMS0500V2	Socket Side Mount 65 316SS	Stainless Steel	17	65
SSMA0500	Socket Side Mount 65 Aluminium Anodised	Aluminium	6	65
SSMG1000	Socket Side Mount 95 GMS	Galvanised Steel	30	95
SSMS1000	Socket Side Mount 95 316SS	Stainless Steel	29	95

## › Flush Mount Socket



- › Suitable for use with our full davit range
- › EN795:2012 certified and meets requirements of IRATA ICOP
- › Suitable for resin fixing into existing concrete
- › Complete with cover and re-bars, for casting into concrete

Product Code	Description	Material	Weight [kg]	Diameter [mm]
SFMG0500	Socket Flush Mount 65 GMS	Galvanised Steel	5	65
SFMS0500	Socket Flush Mount 65 316SS	Stainless Steel	4	65
SFRG0500	Socket Flush Mount Resin Bond 65 GMS	Galvanised Steel	5	65
SFRS0500	Socket Flush Mount Resin Bond 65 316SS	Stainless Steel	4	65
SFMG1000	Socket Flush Mount 95 GMS	Galvanised Steel	9.5	95
SFMS1000	Socket Flush Mount 95 316SS	Stainless Steel	9.5	95
SFRG1000	Socket Flush Mount 95 Resin Bond GMS	Galvanised Steel	9.5	95
SFRS1000	Socket Flush Mount 95 Resin Bond 316SS	Stainless Steel	9.5	95

## > Socket Extensions



- > Can be used with 65mm REID davits combined with 65mm fixed sockets
- > EN795:2012 certified up to 1600mm radius
- > Integrated carry handles
- > Safe use features
- > Maintenance free
- > Manual handling compliant

Product Code	Description	Material	Weight [kg]	Height [mm]
SE0500-0500	Socket Extension 500	Aluminium	12	500
SE0500-0800	Socket Extension 800	Aluminium	15	800
SE0500-1100	Socket Extension 1100	Aluminium	17	1100

## > Socket Pedestals



- > Suitable for use with 65mm REID davits
- > EN795:2012 Certified up to 1600mm radius
- > Secured using 4nr. M16 or M20 anchors [not supplied]
- > Meets requirements of IRATA ICOP up to 1200mm radius
- > Safe use features
- > Maintenance free
- > Manual handling compliant

Product Code	Description	Material	Weight [kg]	Height [mm]
SP0500-0500	Socket Pedestal 65 500mm	Aluminium	17	500
SP0500-0800	Socket Pedestal 65 800mm	Aluminium	19	800
SP0500-1100	Socket Pedestal 65 1100mm	Aluminium	19	1100

## > PORTX Saddle Mount Socket

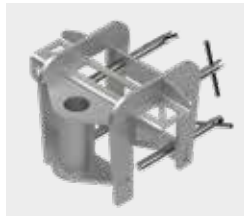

- > EN795:2012 Type B certified
- > Suitable for use with Davits up to a radius of 1200mm
- > Fall arrest capacity – 1 user
- > Personnel capacity up to 150kg\*
- > Goods capacity up to 300kg\*
- > Galvanised steel construction and powder coated finish
- > Designed for use in trenching and shoring applications subject to structural validation

\*Dependant on Davit Operational Arc [See Assembly & Operation Guide for further information]

Product Code	Description	Material	Weight [kg]	Diameter [mm]
PTXTM0-160	PortX Saddle Mount - Max 1200mm Radius	Galvanised Steel	23	65

\* For detailed product drawings see our socket product overview.



## > Customisation

At REID Lifting, we understand the uniquely challenging lifting requirements our clients are faced with which is why we offer a range of customised solutions to ensure that their operational objectives are met, effectively and safely.

From custom designed gantries and davits through to sockets and accessories, our highly experienced team of engineers can support in the design and development of bespoke solutions for niche applications.



## > Extended range

Alongside the products highlighted in this brochure, we also offer a wider range of products, from an extensive **PORTAGANTRY** range through to variant models of the popular **TDAVIT**.

For more information about our extended range and customised solutions, please contact REID Lifting representative or email [enquiries@reidlifting.com](mailto:enquiries@reidlifting.com)











# > Contact Us

## **REID Lifting**

Unit 1 Wyeview,  
Newhouse Farm Ind. Estate  
Chepstow, Monmouthshire  
NP16 6UD UK

- > +44 (0)1291 620 796
- > [enquiries@reidlifting.com](mailto:enquiries@reidlifting.com)
- > [www.reidlifting.com](http://www.reidlifting.com)

All information herein is copyright protected by REID Lifting Ltd. All company and product names are Trade Mark and Trade Name protected and all REID Product IPR is protected under Patents, Patents Pending and/or Design Rights.

 Printed using environment friendly processes and materials.